

Pentair Water Pool and Spa®

PUMP WARNINGS AND SAFETY INSTRUCTIONS

For Pool and Spa Pumps (Non SVRS Pumps)
(Pentair Water Pool and Spa®, Sta-Rite®, and Pentair Pool Products®)



FAILURE TO FOLLOW ALL INSTRUCTIONS AND WARNINGS CAN RESULT IN SERIOUS BODILY INJURY OR DEATH. THIS PUMP SHOULD BE INSTALLED AND SERVICED ONLY BY A QUALIFIED POOL SERVICE PROFESSIONAL. INSTALLERS, POOL OPERATORS AND OWNERS MUST READ THESE WARNINGS AND ALL INSTRUCTIONS IN THE OWNER'S MANUAL BEFORE USING THIS PUMP. THESE WARNINGS AND THE OWNER'S MANUAL MUST BE LEFT WITH THE POOL OWNER.

Warnings and safety instructions for Pentair Water Pool and Spa® pumps and other related products are available at: <http://www.pentairpool.com/pool-owner/safety-warnings/> Call (800) 831-7133 for additional free copies of these instructions. Please refer to www.pentairpool.com for more information related to Pentair Water Pool and Spa® pumps.



SUCTION ENTRAPMENT HAZARD: STAY OFF THE MAIN DRAIN AND AWAY FROM ALL SUCTION OUTLETS!

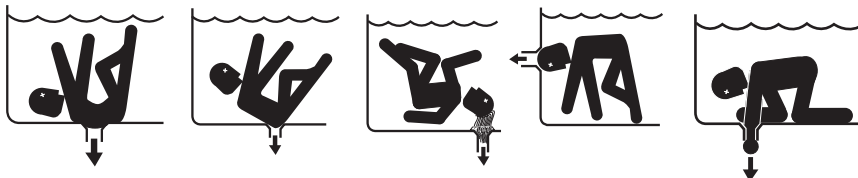

THIS PUMP PRODUCES HIGH LEVELS OF SUCTION AND CREATES A STRONG VACUUM AT THE MAIN DRAIN AT THE BOTTOM OF YOUR POOL AND SPA. THIS SUCTION IS SO STRONG THAT IT CAN TRAP ADULTS OR CHILDREN UNDER WATER IF THEY COME IN CLOSE PROXIMITY TO A POOL OR SPA DRAIN OR A LOOSE OR BROKEN DRAIN COVER OR GRATE.

THE USE OF UNAPPROVED COVERS OR ALLOWING USE OF THE POOL OR SPA WHEN COVERS ARE MISSING, CRACKED OR BROKEN CAN RESULT IN BODY OR LIMB ENTRAPMENT, HAIR ENTANGLEMENT, BODY ENTRAPMENT, EVISCERATION AND/OR DEATH.

The suction at a pool or spa drain or outlet can cause:

Limb Entrapment: When a limb is sucked or inserted into an opening resulting in a mechanical bind or swelling. This hazard is present when a drain cover is missing, broken, loose, cracked or not properly secured.

Hair Entanglement: When the hair tangles or knots in the drain cover, trapping the swimmer underwater. This hazard is present when the flow rating of the cover is too small for the pump or pumps.

Body Entrapment: When a portion of the body is held against the drain cover trapping the swimmer underwater. This hazard is present when the drain cover is missing, broken or the cover flow rating is not high enough for the pump or pumps.

Evisceration/Disembowelment: When a person sits on an open pool (particularly a child wading pool) or spa outlet and suction is applied directly to the intestines, causing severe intestinal damage. This hazard is present when the drain cover is missing, loose, cracked, or not properly secured.

Mechanical Entrapment: When jewelry, swimsuit, hair decorations, finger, toe or knuckle is caught in an opening of an outlet or drain cover. This hazard is present when the drain cover is missing, broken, loose, cracked, or not properly secured.

NOTE: ALL SUCTION PLUMBING MUST BE INSTALLED IN ACCORDANCE WITH THE LATEST NATIONAL AND LOCAL CODES FOR SWIMMING POOLS, SPAS AND HOT TUBS, INCLUDING NSPI STANDARDS AND CPSC GUIDELINES.

READ AND KEEP THESE INSTRUCTIONS FOR FUTURE REFERENCE

© 2010 Pentair Water Pool and Spa, Inc. All rights reserved - Sta-Rite®, Pentair Pool Products® and Pentair Water Pool and Spa® is a registered trademark of Pentair Water Pool and Spa, Inc. Technical Support: (800) 831-7133

P/N 356476 Rev A (08-13-10)



Pentair Water
Pool and Spa®

PUMP (Non SVRS) WARNINGS AND SAFETY INSTRUCTIONS



TO MINIMIZE THE RISK OF INJURY DUE TO SUCTION ENTRAPMENT HAZARD:

- Pools and spas should utilize a minimum of two drains per pump.
- A properly installed and secured ANSI/ASME A112.19.8 approved anti-entrapment suction cover must be used for each drain.
- Each suction cover must be installed at least three (3') feet apart, as measured from the nearest point to nearest point.
- Regularly inspect all covers for cracks, damage and advanced weathering.
- If a cover becomes loose, cracked, damaged, broken or is missing, close the pool or spa immediately, shut off the pump, post a notice and keep the pool or spa closed until an appropriate certified cover is properly installed.
- Replace drain covers as necessary. Drain covers deteriorate over time due to exposure to sunlight, pool chemicals and weather.
- Avoid getting hair, limbs or body in close proximity to any suction cover, pool drain or outlet.
- Use a safety vacuum release system ("SVRS"), suction limiting system or automatic pump shut-off system.
- Disable suction outlets or reconfigure into return inlets.



A clearly labeled emergency shut-off switch for the pool pump and spa jet pump must be in an easily accessible, obvious place near the pool or spa. Make sure bathers know where it is and how to use it in case of emergency.

The Virginia Graeme Baker (VGB) Pool and Spa Safety Act creates new requirements for owners and operators of commercial swimming pools and spas.

Commercial pools or spas constructed on or after December 19, 2008, shall utilize:

- (A) A multiple main drain system without isolation capability with suction outlet covers that meet ASME/ANSI A112.19.8a Suction Fittings for Use in Swimming Pools, Wading Pools, Spas, and Hot Tubs and either:
 - (i) A safety vacuum release system (SVRS) meeting ASME/ANSI A112.19.17 Manufactured Safety Vacuum Release systems (SVRS) for Residential and Commercial Swimming Pool, Spa, Hot Tub, and Wading Pool Suction Systems and/or ASTM F2387 Standard Specification for Manufactured Safety Vacuum Release Systems (SVRS) for Swimming pools, Spas and Hot Tubs or
 - (ii) A properly designed and tested suction-limiting vent system or
 - (iii) An automatic pump shut-off system.

Commercial pools and spas constructed prior to December 19, 2008, with a single submerged suction outlet shall use a suction outlet cover that meets ASME/ANSI A112.19.8a and either:

- (A) A SVRS meeting ASME/ANSI A112.19.17 and/or ASTM F2387, or
- (B) A properly designed and tested suction-limiting vent system, or
- (C) An automatic pump shut-off system, or
- (D) Disabled submerged outlets, or
- (E) Suction outlets shall be reconfigured into return inlets.



HAZARDOUS PRESSURE: STAND CLEAR OF PUMP AND FILTER DURING START-UP

Pool and spa circulation systems operate under high pressure. When any part of the circulating system (i.e. lock ring, pump, filter, valves, etc.) is serviced, air can enter the system and become pressurized.

Pressurized air can cause the pump housing cover filter lid and valves to violently separate which can result in severe personal injury or death. Filter tank lid and strainer cover must be properly secured to prevent violent separation. Stand clear of all circulation system equipment when turning on or starting up pump.

CAUTION!: Electrical controls such as on/off switches, timers, and control systems, etc. should be properly installed to allow the operation (start-up, shut-down, or servicing) of any pump or filter without requiring the user to place any portion of his/her body over or near the pump strainer lid or filter lid. Such installation should allow the user to stand clear of the filter and pump during system start-up, shut down or servicing of the system.

Before servicing pool and spa equipment, make note of the filter pressure. Be sure that all controls are set to ensure the system cannot inadvertently start during service. Turn off all power to the pump. **IMPORTANT: Place filter manual air relief valve in the open position and wait for all pressure in the system to be relieved.**

Before starting the system, fully open the manual air relief valve and place all system valves in the "open" position to allow water to flow freely from the pool and spa back to the pool or spa. Stand clear of all pool and spa equipment and start the pump. **IMPORTANT: Do not close filter manual air relief valve until all pressure has been discharged from the valve and a steady stream of water appears.** Observe filter pressure gauge and be sure it is not higher than the pre-service condition.

STA-RITE®

SuperMax® High Performance Pump



Installation and User's Guide

IMPORTANT SAFETY INSTRUCTIONS
READ AND FOLLOW ALL INSTRUCTIONS
SAVE THESE INSTRUCTIONS

Customer Service

If you have questions about ordering Pentair Water Pool and Spa ("Pentair") replacement parts, and pool products, please use the following contact information:

Customer Service / Technical Support (8 A.M. to 4:30 P.M. — Eastern and Pacific Times)

Phone: (800) 831-7133

Fax: (800) 284-4151

Sanford, North Carolina (8 A.M. to 4:30 P.M. — Eastern Time)

Phone: (919) 566-8000

Fax: (919) 566-8920

Moorpark, California (8 A.M. to 4:30 P.M. — Pacific Time)

Phone: (805) 553-5000 (Ext. 5591)

Fax: (805) 553-5515

Web site

visit www.pentairpool.com and staritepool.com to find information about Pentair products



© 2012 Pentair Water Pool and Spa, Inc. All rights reserved.

This document is subject to change without notice.

1620 Hawkins Ave., Sanford, NC 27330 • (800) 831-7133 • (919) 566-8000

10951 West Los Angeles Ave., Moorpark, CA 93021 • (800) 831-7133 • (805) 553-5000

Trademarks and Disclaimers: SuperMax®, Pentair Pool Products®, Because reliability matters most®, Sta-Rite®, and Pentair Water Pool and Spa® are trademarks and/or registered trademarks of Pentair Water Pool and Spa, Inc. and/or its affiliated companies in the United States and/or other countries. Century® is a registered trademark of Regal Beloit EPC, Inc., Franklin Electric® is a registered trademark of Franklin Electric Co., Inc., and AO Smith® is a registered trademark of A.O. Smith, Corp. Unless noted, names and brands of others that may be used in this document are not used to indicate an affiliation or endorsement between the proprietors of these names and brands and Pentair Water Pool and Spa, Inc. Those names and brands may be the trademarks or registered trademarks of those parties or others.

Table of Contents

Important Warning and Safety Instructions.....	ii
Section 1: Introduction	1
SuperMax® Pump Overview.....	1
General Features	2
Section 2: Electrical Requirements	3
Wiring Installation.....	3
Section 3: Maintenance	5
Pump Strainer Basket	5
Cleaning the Pump Strainer Basket.....	5
Winterizing	7
Electric Motor Care	7
Section 4: Servicing	8
Pump Disassembly	8
Pump Reassembly/Seal Replacement	9
Shaft Seal	9
Section 5: Restart Instructions	10
Priming the Pump	10
Section 6: Troubleshooting	11
Section 7: Technical Data	12
Illustrated Parts List	12
Pump Curve	13

Pentair Water Pool and Spa®
PUMP WARNING AND SAFETY INSTRUCTIONS
For Pool and Spa Pumps (Non SVRS Pumps)
(Pentair Water Pool and Spa®, Sta-Rite®, and Pentair Pool Products®)

Warnings and safety instructions for Pentair Water Pool and Spa® pumps and other related products are available at: <http://www.pentairpool.com/pool-owner/safety-warnings/> or call (800) 831-7133 for additional free copies of these instructions.

Please refer to <http://www.pentairpool.com/pool-owner/safety-warnings/> for warning and safety instructions related to the SuperMax® High Performance Pump.

READ AND FOLLOW ALL WARNING AND SAFETY INSTRUCTIONS



This is the safety alert symbol. When you see this symbol on your system or in this manual, look for one of the following signal words and be alert to the potential for personal injury.

DANGER

Warns about hazards that can cause death, serious personal injury, or major property damage if ignored.

WARNING

Warns about hazards that may cause death, serious personal injury, or major property damage if ignored.

CAUTION

Warns about hazards that may or can cause minor personal injury or property damage if ignored.

NOTE indicates special instructions not related to hazards.

Carefully read and follow all safety instructions in this manual and on equipment. Keep safety labels in good condition; replace if missing or damaged.

DANGER

FAILURE TO FOLLOW ALL INSTRUCTIONS AND WARNINGS CAN RESULT IN SERIOUS BODILY INJURY OR DEATH. THIS PUMP SHOULD BE INSTALLED AND SERVICED ONLY BY A QUALIFIED POOL SERVICE PROFESSIONAL. INSTALLERS, POOL OPERATORS AND OWNERS MUST READ THESE WARNINGS AND ALL INSTRUCTIONS IN THE OWNER'S MANUAL BEFORE USING THIS PUMP. THESE WARNINGS AND THE OWNER'S MANUAL MUST BE LEFT WITH THE POOL OWNER.

DANGER

SUCTION ENTRAPMENT HAZARD: STAY OFF THE MAIN DRAIN AND AWAY FROM ALL SUCTION OUTLETS!



THIS PUMP PRODUCES HIGH LEVELS OF SUCTION AND CREATES A STRONG VACUUM AT THE MAIN DRAIN AT THE BOTTOM OF YOUR POOL AND SPA. THIS SUCTION IS SO STRONG THAT IT CAN TRAP ADULTS OR CHILDREN UNDER WATER IF THEY COME IN CLOSE PROXIMITY TO A POOL OR SPA DRAIN OR A LOOSE OR BROKEN DRAIN COVER OR GRATE.

READ AND KEEP THESE INSTRUCTIONS FOR FUTURE REFERENCE

Pentair Water Pool and Spa® PUMP WARNING AND SAFETY INSTRUCTIONS For Pool and Spa Pumps (Non SVRS Pumps) (Pentair Water Pool and Spa®, Sta-Rite®, and Pentair Pool Products®)

THE USE OF UNAPPROVED COVERS OR ALLOWING USE OF THE POOL OR SPA WHEN COVERS ARE MISSING, CRACKED OR BROKEN CAN RESULT IN BODY OR LIMB ENTRAPMENT, HAIR ENTANGLEMENT, BODY ENTRAPMENT, EVISCERATION AND/OR DEATH.

The suction at a pool or spa drain or outlet can cause:

Limb Entrapment: When a limb is sucked or inserted into an opening resulting in a mechanical bind or swelling. This hazard is present when a drain cover is missing, broken, loose, cracked or not properly secured.

Hair Entanglement: When the hair tangles or knots in the drain cover, trapping the swimmer underwater. This hazard is present when the flow rating of the cover is too small for the pump or pumps.

Body Entrapment: When a portion of the body is held against the drain cover trapping the swimmer underwater. This hazard is present when the drain cover is missing, broken or the cover flow rating is not high enough for the pump or pumps.

Evisceration/Disembowelment: When a person sits on an open pool (particularly a child wading pool) or spa outlet and suction is applied directly to the intestines, causing severe intestinal damage. This hazard is present when the drain cover is missing, loose, cracked, or not properly secured.

Mechanical Entrapment: When jewelry, swimsuit, hair decorations, finger, toe or knuckle is caught in an opening of an outlet or drain cover. This hazard is present when the drain cover is missing, broken, loose, cracked, or not properly secured.

NOTE: ALL SUCTION PLUMBING MUST BE INSTALLED IN ACCORDANCE WITH THE LATEST NATIONAL AND LOCAL CODES FOR SWIMMING POOLS, SPAS AND HOT TUBS, INCLUDING NSPI STANDARDS AND CPSC GUIDELINES.

WARNING

TO MINIMIZE THE RISK OF INJURY DUE TO SUCTION ENTRAPMENT HAZARD:

- Pools and spas should utilize a minimum of two drains per pump.
- A properly installed and secured ANSI/ASME A112.19.8 approved anti-entrapment suction cover must be used for each drain.
- Each suction cover must be installed at least three (3') feet apart, as measured from the nearest point to nearest point.
- Regularly inspect all covers for cracks, damage and advanced weathering.
- If a cover becomes loose, cracked, damaged, broken or is missing, close the pool or spa immediately, shut off the pump, post a notice and keep the pool or spa closed until an appropriate certified cover is properly installed.
- Replace drain covers as necessary. Drain covers deteriorate over time due to exposure to sunlight, pool chemicals and weather.
- Avoid getting hair, limbs or body in close proximity to any suction cover, pool drain or outlet.
- Disable suction outlets or reconfigure into return inlets.

WARNING

A clearly labeled emergency shut-off switch for the pool pump and spa jet pump must be in an easily accessible, obvious place near the pool or spa. Make sure bathers know where it is and how to use it in case of emergency.

Pentair Water Pool and Spa®
PUMP WARNING AND SAFETY INSTRUCTIONS
For Pool and Spa Pumps (Non SVRS Pumps)
(Pentair Water Pool and Spa®, Sta-Rite®, and Pentair Pool Products®)

The Virginia Graeme Baker (VGB) Pool and Spa Safety Act creates new requirements for owners and operators of commercial swimming pools and spas.

Commercial pools or spas constructed on or after December 19, 2008, shall utilize:

- (A) A multiple main drain system without isolation capability with suction outlet covers that meet ASME/ANSI A112.19.8a Suction Fittings for Use in Swimming Pools, Wading Pools, Spas, and Hot Tubs and either:
 - (i) A safety vacuum release system (SVRS) meeting ASME/ANSI A112.19.17 Manufactured Safety Vacuum Release systems (SVRS) for Residential and Commercial Swimming Pool, Spa, Hot Tub, and Wading Pool Suction Systems and/or ASTM F2387 Standard Specification for Manufactured Safety Vacuum Release Systems (SVRS) for Swimming pools, Spas and Hot Tubs or
 - (ii) A properly designed and tested suction-limiting vent system or
 - (iii) An automatic pump shut-off system.

Commercial pools and spas constructed prior to December 19, 2008, with a single submerged suction outlet shall use a suction outlet cover that meets ASME/ANSI A112.19.8a and either:

- (A) A SVRS meeting ASME/ANSI A112.19.17 and/or ASTM F2387, or
- (B) A properly designed and tested suction-limiting vent system, or
- (C) An automatic pump shut-off system, or
- (D) Disabled submerged outlets, or
- (E) Suction outlets shall be reconfigured into return inlets.



HAZARDOUS PRESSURE: STAND CLEAR OF PUMP AND FILTER DURING START-UP

Pool and spa circulation systems operate under high pressure. When any part of the circulating system (i.e. lock ring, pump, filter, valves, etc.) is serviced, air can enter the system and become pressurized. Pressurized air can cause the pump housing cover filter lid and valves to violently separate which can result in severe personal injury or death. Filter tank lid and strainer cover must be properly secured to prevent violent separation. Stand clear of all circulation system equipment when turning on or starting up pump.

Before servicing pool and spa equipment, make note of the filter pressure. Be sure that all controls are set to ensure the system cannot inadvertently start during service. Turn off all power to the pump.

IMPORTANT: Place filter manual air relief valve in the open position and wait for all pressure in the system to be relieved.

Before starting the system, fully open the manual air relief valve and place all system valves in the “open” position to allow water to flow freely from the pool and spa back to the pool or spa. Stand clear of all pool and spa equipment and start the pump.

IMPORTANT: Do not close filter manual air relief valve until all pressure has been discharged from the valve and a steady stream of water appears. Observe filter pressure gauge and be sure it is not higher than the pre-service condition.

Pentair Water Pool and Spa®
PUMP WARNING AND SAFETY INSTRUCTIONS
For Pool and Spa Pumps (Non SVRS Pumps)
(Pentair Water Pool and Spa®, Sta-Rite®, and Pentair Pool Products®)

General Installation Information

- All work must be performed by a qualified pool professional, and must conform to all national, state, and local codes.
- Install to provide drainage of compartment for electrical components.
- These instructions contain information for a variety of pump models and therefore some instructions may not apply to a specific model. All models are intended for use in swimming pool applications. The pump will function correctly only if it is properly sized to the specific application and properly installed.

⚠ WARNING Pumps improperly sized or installed or used in applications other than for which the pump was intended can result in severe personal injury or death. These risks may include but not be limited to electric shock, fire, flooding, suction entrapment or severe injury or property damage caused by a structural failure of the pump or other system component.

⚠ WARNING The pump can produce high levels of suction within the suction side of the plumbing system. These high levels of suction can pose a risk if a person comes within the close proximity of the suction openings. A person can be seriously injured by this high level of vacuum or may become trapped and drown. It is absolutely critical that the suction plumbing be installed in accordance with the latest national and local codes for swimming pools.

General Warnings

⚠ WARNING **Risk of Electrical Shock.** Connect only to a branch circuit protected by a ground-fault circuit-interrupter (GFCI). Contact a qualified electrician if you cannot verify that the circuit is protected by a GFCI.

⚠ WARNING This unit must be connected only to a supply circuit that is protected by a ground-fault circuit-interrupter (GFCI). Such a GFCI should be provided by the installer and should be tested on a routine basis. To test the GFCI, push the test button. The GFCI should interrupt power. Push the reset button. Power should be restored. If the GFCI fails to operate in this manner, the GFCI is defective.

⚠ WARNING If the GFCI interrupts power to the pump without the test button being pushed, a ground current is flowing, indicating the possibility of an electric shock. Do not use this pump. Disconnect the pump and have the problem corrected by a qualified service representative before using.

⚠ CAUTION This pump is for use with permanent swimming pools and may also be used with hot tubs and spas if so marked. Do not use with storable pools. A permanently-installed pool is constructed in or on the ground or in a building such that it cannot be readily disassembled for storage. A storable pool is constructed so that it is capable of being readily disassembled for storage and reassembled to its original integrity.

⚠ CAUTION Electrical controls such as on/off switches, timers, and control systems, etc. should be properly installed to allow the operation (start-up, shut-down, or servicing) of any pump or filter without requiring the user to place any portion of his/her body over or near the pump strainer lid or filter lid. Such installation should allow the user to stand clear of the filter and pump during system start-up, shut down or servicing of the system.

Pentair Water Pool and Spa®
PUMP WARNING AND SAFETY INSTRUCTIONS
For Pool and Spa Pumps (Non SVRS Pumps)
(Pentair Water Pool and Spa®, Sta-Rite®, and Pentair Pool Products®)

General Warnings, (Continued).

- Never open the inside of the drive motor enclosure. There is a capacitor bank that holds a 230 VAC charge even when there is no power to the unit.
- The pump is not submersible
- The pump is capable of high flow rates; use caution when installing and programming to limit pumps performance potential with old or questionable equipment
- Code requirements for the electrical connection differ from state to state. Install equipment in accordance with the National Electrical Code and all applicable local codes and ordinances.
- Before servicing the pump; press the Stop button and disconnect the communication cable, then switch OFF power to the pump by disconnecting the main circuit to the pump.
- This appliance is not intended for use by persons (including children) of reduced physical, sensory or mental capabilities, or lack of experience and knowledge, unless they have been given supervision or instruction concerning the use of the appliance by a person responsible for their safety.
- To reduce the risk of injury, do not permit children to use this product unless they are closely supervised at all times.

NOTICE: All suction plumbing must be installed in accordance with the latest national and local codes for swimming pools, spas and hot tubs, including nsfi standards and CPSC guidelines.

SAVE THESE INSTRUCTIONS

Section 1

Introduction

SuperMax® High Performance Pump Overview

The perfect choice for all types of pools, the SuperMax® was specifically designed to be your best choice for a variety of inground pools. Thick walled body parts, a heavy duty 56 square flange motor, and highly engineered hydraulics make this rugged and tested design perfect for any pool, spa, water feature, or fountain. And SuperMax's silent running capability and small footprint allow it to easily drop into a compact equipment pad.

Efficient, Quiet, Rugged, and Versatile

All pumps from Sta-Rite® incorporate innovative hydraulic engineering that has been refined for over 40 years. SuperMax® reflects the latest and best Pentair technology, to move water more efficiently for lower operational costs. Compact, rugged, and easy to maintain, SuperMax® will deliver years of reliable service.



SuperMax® Pump

General Features

- Extremely quiet operation
- Unionized fittings (1.5" and 2") for simple replacement
- Cam and Ramp™ lid for easy cleaning and maintenance
- Heavy-duty, high service factor 56 square flange motor for long life
- Integral volute and pot reduce hydraulic noise
- See-through lid permits easy inspection of strainer basket

Additional Features:

- 115 volt or 230 volt models available
- 1/2 Hp to 2 1/2 Hp configurations to accommodate a wide range of applications
- Self-priming for quick, easy start-up
- Every SuperMax® pump is performance and pressure tested prior to shipment to ensure superior quality
- UL/CUL/NSF

Section 2

Electrical Requirements

This section describes how to wire the SuperMax® pump.

Note: Before installing this product, read and follow all warning notices and instructions on pages ii-vi.

Electrical Requirements and Wiring

 **WARNING** — Risk of electrical shock or electrocution.



This pool pump must be installed by a licensed or certified electrician or a qualified pool serviceman in accordance with the National Electrical Code and all applicable local codes and ordinances. Improper installation will create an electrical hazard which could result in death or serious injury to pool users, installers, or others due to electrical shock, and may also cause damage to property.

Always disconnect power to the pool pump at the circuit breaker before servicing the pump. Failure to do so could result in death or serious injury to serviceman, pool users or others due to electric shock.

Wiring Installation

1. Be sure all electrical breakers and switches are turned off before wiring motor.
2. Be sure that the wiring voltage matches the motor voltage (230 VAC or 115 VAC). If they do not match, the motor can overheat.
3. Choose a wire size from the Chart 1. When in doubt use a heavier gauge (larger diameter) wire. Heavier gauge will allow the motor to run cooler and more efficient.
4. Be sure all electrical connections are clean and tight.
5. Cut wires to the appropriate length so they do not overlap or touch when connected to the terminal board.

Chart 1.

SUPPLY WIRE SIZES (AWG)						
(Size and Length by Horsepower)						
Hp	115 volts			230 volts		
	50 ft.	100 ft.	150 ft.	50 ft.	100 ft.	150 ft.
1/3	14	14	12	14	14	14
1/2	14	12	10	14	14	14
3/4	12	12	10	14	14	14
1	12	10	8	14	14	14
1½	10	10	8	14	14	12
2	10	8	8	14	12	12
2½	-	-	-	12	12	10
3	-	-	-	12	12	10

Wiring Installation, (Continued).

6. Permanently ground the motor using the green ground terminal located on the inside of the motor canopy or access plate, see **Figure 1**. Use the correct wire size and type specified by National Electrical Code. Make sure the ground wire is connected to an electrical service ground.
7. Bond the motor to the pool structure in accordance with the National Electrical Code. UL requires use of a solid copper bonding conductor not smaller than 8 AWG.
8. Connect the wire from the accessible wire connector on the motor to all metal parts of the swimming pool, spa, or hot tub structure and to all electrical equipment, metal conduit, and metal piping within 5 feet of the inside walls of the swimming pool, spa, or hot tub. For Canada, a 6 AWG or larger solid copper bonding conductor is required.
9. The pump should be permanently connected to either a circuit breaker, 2-pole timer or 2-pole relay. If AC power is supplied by a GFCI circuit breaker, use a dedicated circuit breaker that has no other electrical loads.
10. Connect the pump permanently to a circuit. Make sure no other lights or appliances are on the same circuit.

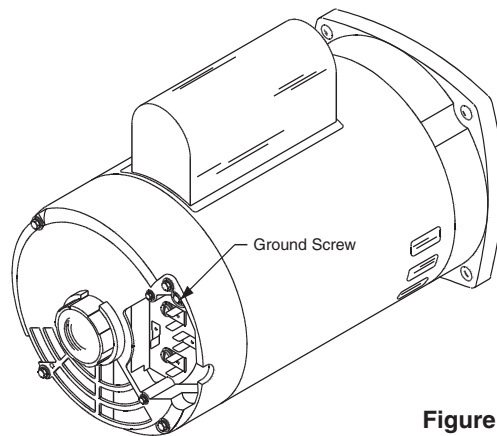

Figure 1.

Section 3

Maintenance

This section describes how to maintain the SuperMax® pump.

The Pump Strainer Basket

This unit, sometimes referred to as the ‘Hair and Lint Pot’, is the unit in front of the volute. Inside the chamber is the basket which must be kept clean of leaves and debris at all times. View basket through the ‘See Through Lid’ to inspect for leaves and debris.

Regardless of the length of time between filter cleaning, it is most important to visually inspect the hair and lint pot basket at least once a week. A clogged basket reduces the efficiency of the filter and heater and puts added stress on the pump motor.

Cleaning the Pump Strainer Basket

WARNING — **DO NOT** open the strainer pot if pump fails to prime or if pump has been operating without water in the strainer pot. Pumps operated in these circumstances may experience a build up of vapor pressure and may contain scalding hot water. Opening the pump may cause serious personal injury. In order to avoid the possibility of personal injury, make sure the suction and discharge valves are open and strainer pot temperature is cool to touch, then open with extreme caution.

CAUTION — To prevent damage to the pump and filter and for proper operation of the system, clean pump strainer and skimmer baskets regularly.

1. Turn off motor.
2. Relieve pressure in the system.
3. Turn the clamp and lid in a counter-clockwise direction until it stops.
4. Turn the clamp and lid set to remove the clamp and lid.
5. Put the debris from the basket into the trash and rinse the basket. Replace the basket if cracked.
6. Replace the basket. Be sure to align the slot in the basket with the rib in the volute, see [Figure 2](#).
7. Fill the pump pot and volute up to the inlet port with water.
8. Clean the cover, cover O-ring, and sealing surface of the pump pot. Grease the O-ring with a silicone based lubricant.

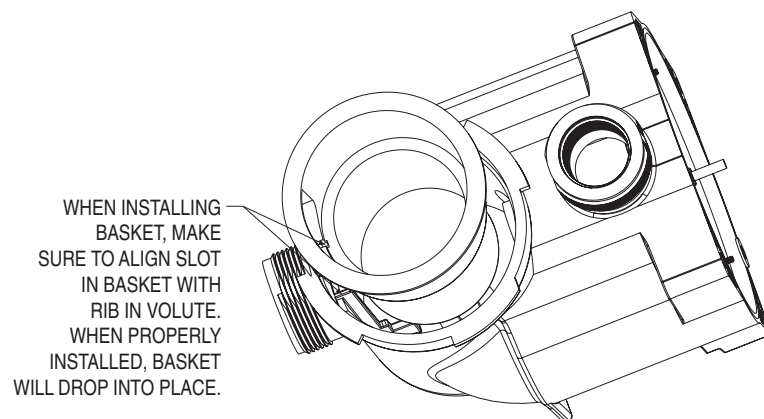

Figure 2.

Cleaning the Pump Strainer Basket, (Continued).

9. Reinstall the lid by placing the clamp and the lid on the pot; see [Figure 3](#).
10. Be sure the lid O-ring is properly placed. Seat the clamp and lid then turn clockwise until the handles are horizontal; see [Figure 4](#).

⚠ WARNING — THIS FILTER OPERATES UNDER HIGH PRESSURE.



When any part of the circulating system (e.g., Lock Ring, Pump, Filter, Valves, etc.) is serviced, air can enter the system and become pressurized. Pressurized air can cause the lid to separate which can result in severe injury, death, or property damage. To avoid this potential hazard, follow these instructions.

11. Turn the power “ON” at the house circuit breaker. Reset the pool time clock to the correct time
12. Open the manual air relief valve on top of the filter.
13. Stand clear of the filter. Start the pump.
14. Bleed air from the filter until a steady stream of water comes out. Close the manual air relief valve.

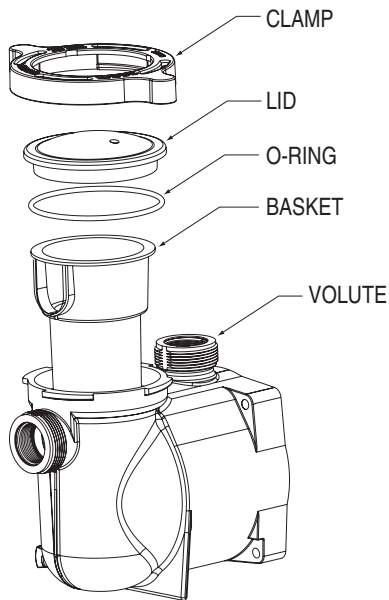

Figure 3.

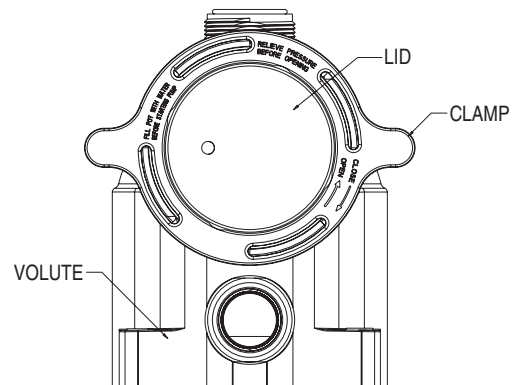

Figure 4.

Winterizing

1. If the air temperature drops below 35° F., the water in the pump can freeze and cause damage. Freeze damage is not warrantable.
2. To prevent freeze damage follow the procedures listed below:
 - Shut off electrical power for the pump at the house circuit breaker.
 - Drain the water out of the pump case by removing the two thumb-twist drain plugs from the case. Store the plugs in the pump basket.
 - Cover the motor to protect it from severe rain, snow and ice.
 - Do not wrap the motor in plastic. It will cause condensation and rust on the inside of the motor.



CAUTION — In mild climate area, when temporary freezing conditions may occur, run your filtering equipment all night to prevent freezing.

Care of Electric Motor

1. Protect from heat.
 - Shade the motor from the sun.
 - Any enclosure must be well ventilated to prevent overheating.
 - Provide ample cross ventilation.
2. Protect against dirt.
 - Protect from any foreign matter or splashing water.
 - Do not store (or spill) pool chemicals near the motor.
 - Avoid sweeping or stirring up dust near the motor while in operation.
 - If a motor has been damaged by dirt it voids the motor warranty.
3. Protect against moisture.
 - Protect from splashing pool water and lawn sprinklers.
 - Protect from the weather.
 - If a motor has become wet - let it dry before operating. Do not allow the pump to operate if it has been flooded.
 - If a motor has been damaged by water it voids the motor warranty.

NOTE

- **DO NOT** wrap motor with plastic or other air tight materials. The motor may be covered during a storm, for winter storage, etc., but never when operating, or expecting operation.
 - When replacing the motor, be certain that the motor support is correctly positioned to support the size of motor being installed.
-

Section 4

Servicing

This section describes how to service the SuperMax® pump.

WARNING — Risk of electrical shock or electrocution.



This pool pump must be installed by a licensed or certified electrician or a qualified pool serviceman in accordance with the National Electrical Code and all applicable local codes and ordinances. Improper installation will create an electrical hazard which could result in death or serious injury to pool users, installers, or others due to electrical shock, and may also cause damage to property.

Always disconnect power to the pool pump at the circuit breaker before servicing the pump. Failure to do so could result in death or serious injury to serviceman, pool users or others due to electric shock.

Read all servicing instructions before working on the pump.

WARNING — **DO NOT** open the strainer pot if pump fails to prime or if pump has been operating without water in the strainer pot. Pumps operated in these circumstances may experience a build up of vapor pressure and may contain scalding hot water. Opening the pump may cause serious personal injury. In order to avoid the possibility of personal injury, make sure the suction and discharge valves are open and strainer pot temperature is cool to touch, then open with extreme caution.



CAUTION — Be sure not to scratch or mar the polished shaft seal faces; seal will leak if faces are damaged.

Pump Disassembly

1. All moving parts are located in the rear sub-assembly of this pump.

Required Tools:

- 1/4 inch socket or open end wrench.
 - 3/8 inch socket or open end wrench.
 - 9/16 inch open end wrench.
 - Flat blade screwdriver.
2. To remove and repair the motor sub-assembly perform the following procedures:
 - a. Turn off the pump circuit breaker at the main panel.
 - b. Drain the pump by removing the drain plugs.
 - c. Remove the 4 bolts that hold the main pump body (strainer pot/volute) to the rear sub-assembly.
 - d. GENTLY pull the two pump halves apart, removing the rear sub-assembly.
 - e. Remove the three hex head screws holding the diffuser in position.
 - f. Hold the impeller securely in place and remove the impeller lock screw by using a flat blade screwdriver or wrench. The screw is a left-handed thread and loosens in a clockwise direction.
 - g. Remove the shaft cap located at the back of the motor and hold the shaft secure with a 1/2 inch (Century® motors) or 7/16 inch (Franklin Electric® Motors) open-end wrench. On AO Smith® motors, remove the motor canopy, move the capacitor to one side and hold the shaft with a 7/16 inch open-end wrench.
 - h. To unscrew the impeller from the shaft, twist the impeller counter-clockwise.
 - i. Remove the four bolts from the seal plate to the motor using a 3/8 inch wrench.
 - j. Place the seal plate face down on a flat surface and tap out the ceramic seal.
 - k. Clean the seal plate, seal housing, and the motor shaft.

Pump Reassembly/Seal Replacement

1. When installing the replacement seal into the seal plate, use soapy water to wet the rubber boot before pressing it into the seal plate.
2. Remount the seal plate to the motor.
3. Before installing the rotating portion of the seal on the motor shaft, wet the motor shaft with soapy water and slide the seal onto the motor shaft. Ensure that the carbon face contacts the ceramic face of the stationary seat. Press the seal into the seal plate with your thumbs and wipe off the ceramic with a clean cloth.
4. Grease the motor shaft thread and screw impeller onto the motor shaft.
5. Screw in the impeller lock screw (counter-clockwise to tighten).
6. Remount the diffuser onto the seal plate. Make sure the plastic pins and holding screw inserts are aligned.
7. Grease the diffuser quad ring and seal plate O-ring prior to reassembly.
8. Grease the bolt threads, assemble the motor sub-assembly to the strainer pot-pump body by using the two through bolts for proper alignment. Do not tighten the through bolts until all 4 bolts are in place and finger tightened.
9. Fill the pump with water.
10. Reinstall the pump lid and plastic clamp; see [SECTION 3, Maintenance](#).
11. Reprime the system.

The Shaft Seal

1. The Shaft Seal consists primarily of two parts, a rotating member and a ceramic seal.
2. The pump requires little or no service other than reasonable care, however, a Shaft Seal may occasionally become damaged and must be replaced.

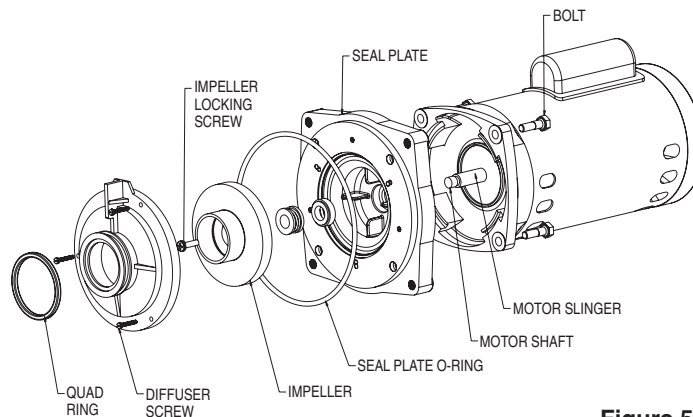



Figure 5.

Section 5

Restart Instructions

If the SuperMax® pump is installed below the water level of the pool, close return and suction lines prior to opening hair and lint pot on pump. Make sure to reopen valves prior to operating.

 **CAUTION** — DO NOT run the pump dry. If the pump is run dry, the mechanical seal will be damaged and the pump will start leaking. If this occurs, the damaged seal must be replaced. ALWAYS maintain proper water level in your pool (half way up skimmer opening). If the water level falls below the skimmer opening, the pump will draw air through the skimmer, losing the prime and causing the pump to run dry, resulting in a damaged seal. Continued operation in this manner could cause a loss of pressure, resulting in damage to the pump case, impeller and seal, and may cause property damage and personal injury.

Priming the Pump

1. The pump strainer pot must be filled with water before the pump is initially started. Follow these steps to prime the pump.
 - a. Remove the pump lid plastic clamp. Remove the pump lid.
 - b. Fill the pump strainer pot with water.
 - c. Reassemble the pump cover and plastic clamp onto the strainer pot. The pump is now ready to prime.
 - d. Open the air release valve on the filter, and stand clear of the filter.
 - e. Turn on the switch or time clock.
 - f. When water comes out of the air release valve, close the valve. The system should now be free of air and recirculating water to and from the pool.
2. For 2-speed pumps:
 - a. Pump should run on high-speed for priming.
 - b. The pump should not run longer than 8 minutes before priming is achieved.

Section 6

Troubleshooting

Use the following troubleshooting information to resolve possible problems with your SuperMax® pump.

WARNING — RISK OF ELECTRICAL SHOCK OR ELECTROCUTION.

Improperly installation will create an electrical hazard which could result in death or serious injury to pool users, installers, or others due to electrical shock, and may also cause damage to property.



1. If you are not familiar with your pool filtering system and/or heater:
 - a. **Do NOT** attempt to adjust or service without consulting your dealer, or a qualified pool technician.
 - b. Read the entire Installation & User's Guide before attempting to use, service or adjust the pool filtering system or heater.

Note: Turn off power to unit prior to attempting service or repair.

Problems and Corrective Actions

<i>Problem</i>	<i>Corrective Action</i>
FAILURE TO PUMP Pump Will Not Prime — too much air	Check suction piping and valve glands on any suction gate valves. Secure lid on pump strainer pot and make sure lid gasket is in place. Check water level to make sure skimmer is not drawing air.
Pump Will Not Prime — not enough water Pump strainer clogged	Make sure suction lines, pump strainer, and pump volute are full of water. Make sure valve on suction line is working and open, (some systems do not have valves). Check water level to make sure water is available through skimmer. Clean pump strainer pot.
Pump strainer gasket defective	Replace gasket.
REDUCED CAPACITY and/or HEAD Air pockets or leaks in suction line Pump Will Not Prime — too much air	Check suction piping and valve glands on any suction gate valves. Secure lid on pump strainer pot and make sure lid gasket is in place. Check water level to make sure skimmer is not drawing air.
Clogged impeller	Turn off electrical power to the pump. Remove the clamp that holds the volute to the seal plate. Slide the motor and seal plate away from the volute. Clean debris from impeller. If debris cannot be removed, complete the following steps. <ol style="list-style-type: none"> (1) Remove left hand thread anti-spin bolt and O-ring. (2) Remove, clean and reinstall impeller. (3) Reinstall anti-spin bolt. Reinstall diffuser and quad ring. Reinstall motor and seal plate into volute. Reinstall clamp around seal plate and volute and tighten securely.
Pump strainer clogged	Clean suction trap.

Section 7

Technical Data

Illustrated Parts List

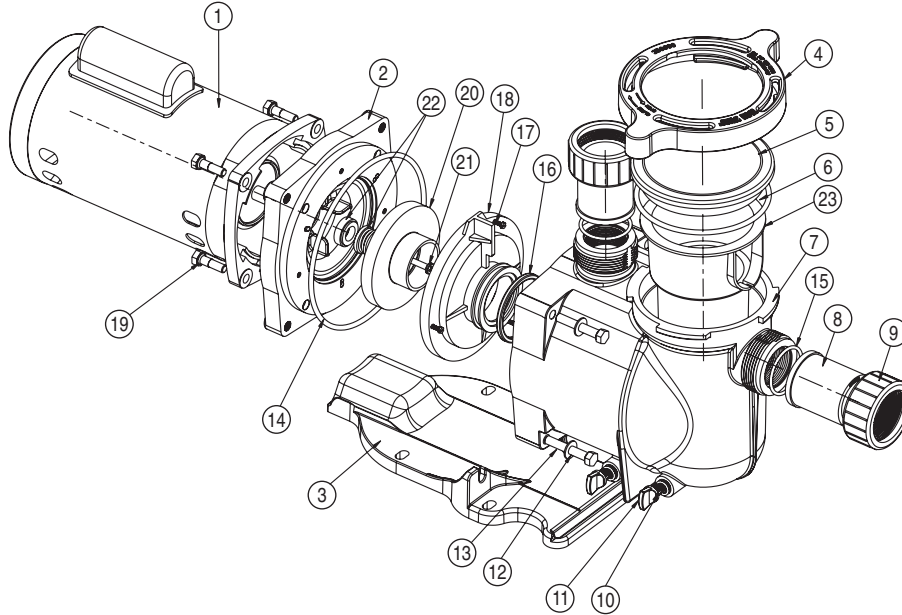

Item No.	Part No.	Description
SINGLE SPEED SUPERMAX MOTORS		
1	355019S	1/2, 3/4 HP — (Black)
1	355021S	1 HP — (Black)
1	355023S	1 1/2 HP — (Black)
1	355025S	2 HP — (Black)
1	355027S	2 1/2 HP — (Black)
DUAL SPEED SUPERMAX MOTORS		
1	355232S	1 HP — (Black)
1	355376S	1 1/2 HP — (Black)
1	355377S	2 HP — (Black)
ENERGY EFFICIENT SUPERMAX MOTORS		
1	355375S	3/4 HP 115 VOLTAGE — (Black)
1	355391S	1/2, 3/4, 1HP — (Black)
1	355392S	1 1/2 HP — (Black)
1	355393S	2 HP — (Black)
1	355394S	2 1/2 HP — (Black)
2	355612	SEAL PLATE
3	351094	BASE
4	351090	CLAMP, RAMP & CAM
5	350091	LID
6	357255	O-RING, LID #2-357
7	351089	VOLUTE
8	350093	ADAPTER, 2 req.
9	270141	NUT, 2 req.
10	192115	O-RING DRAIN PLUG, 2 req.
11	357161	DRAIN PLUG, 2 req.

Item No.	Part No.	Description
12	355621	SCREW 3/4-16 X 2 1/4 HEX HD, 4 req.
13	072184	WASHER 3/8 in. S/S, 4 req.
14	355619	O-RING SEAL BRACKET
15	350099	O-RING ADAPTER #2-226, 2 req.
16	355030	SEAL DIFFUSER
17	355334	SCREW #8-32 HEX WASHER HD, 3 req.
18	355617	DIFFUSER - 1/2 HP
18	355617	DIFFUSER - 3/4 HP
18	355617	DIFFUSER - 1 HP
18	355618	DIFFUSER - 1 1/2 HP
18	355618	DIFFUSER - 2 HP
18	350170	DIFFUSER - 2 1/2 HP
19	354290	HEX HEAD SCREW 3/8 - 16, 4 req.
20	355043	IMPELLER 1/2 HP
20	355043	IMPELLER 3/4 HP
20	355067	IMPELLER 1 HP
20	355074	IMPELLER 1 1/2 HP
20	355086	IMPELLER 2 HP
20	355093	IMPELLER 2 1/2 HP
20	355067	IMPELLER 1 HP, 2-SPD
20	355074	IMPELLER 1 1/2 HP, 2-SPD
20	355086	IMPELLER 2 HP, 2-SPD
21	355389	SCREW, IMPELLER LOCKING
22	354545	SEAL SET
23	355667	BASKET, LARGE
24	351157	SUPERMAX® UNION KIT(2 UNIONS, 2 ADAPTERS, 2 O-RINGS PER KIT)

Pump Curve

Pentair Water Pool and Spa, Inc.
 Pump Performance Curve
 SuperMax® Series

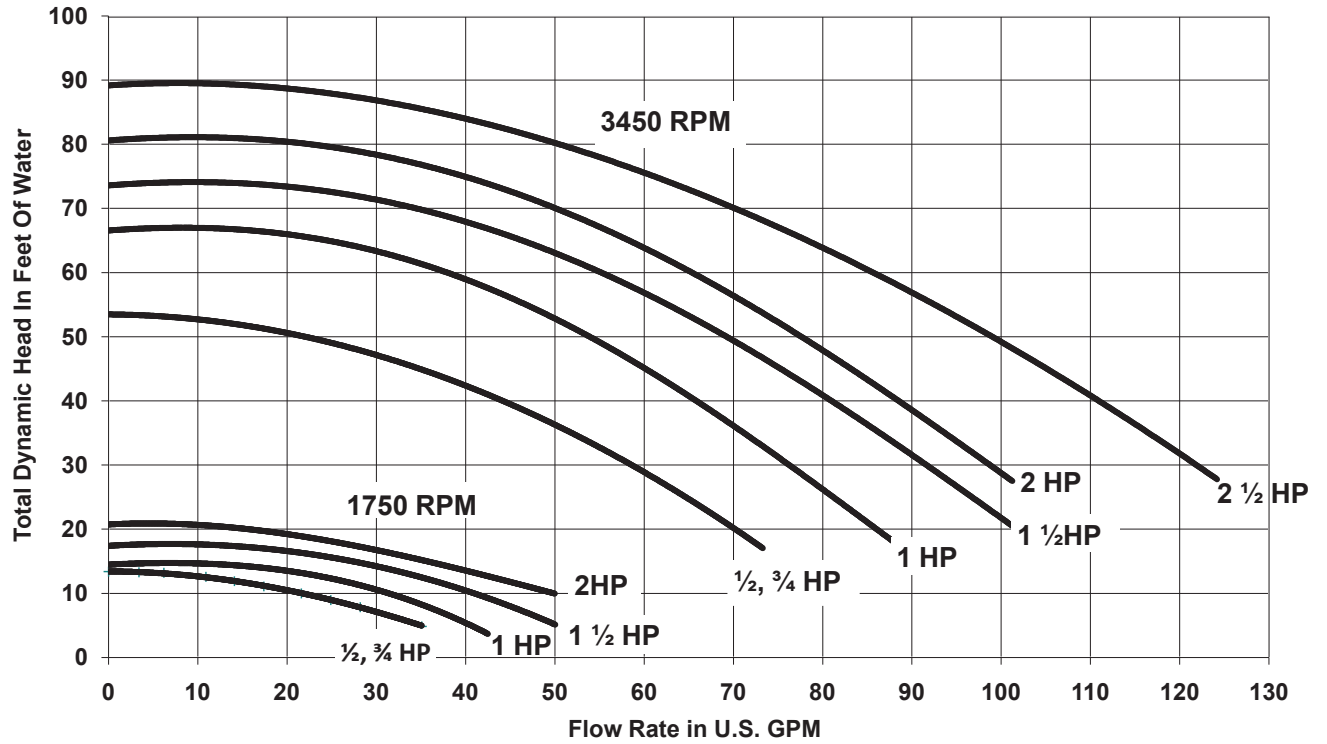

NOTES

SAVE THESE INSTRUCTIONS



LIT PKG. P/N 354708

STA-RITE®



P/N 351096 Rev. F 2/22/12