

English

195  
PO

## IMPORTANT SAFETY RULES

Read, understand, and follow  
all instructions carefully before  
installing and using this product.

Model SF80110

Model SF70110

Model SF60110



For illustrative purposes only.

Don't forget to try these other fine Intex products: pools, pool accessories, inflatable pools and in-home toys, airbeds and boats available at fine retailers or visit our website.

Due to a policy of continuous product improvement, Intex reserves the right to change specifications and appearance, which may result in updates to the instruction manual without notice.



## IMPORTANT! DO NOT RETURN PRODUCT TO STORE

To purchase parts and accessories or to obtain non-technical assistance, visit

[www.intexcorp.com](http://www.intexcorp.com)

For technical assistance and missing parts call us toll-free (for U.S. and Canadian Residents):

**1-800-234-6839**

Monday through Friday, 8:30am to 5:00pm Pacific Time

195-PO-R0-1406

OWNER'S MANUAL

## TABLE OF CONTENTS

<b>Warnings.....</b>	<b>3</b>
<b>Parts References.....</b>	<b>4-5</b>
<b>Setup Instructions .....</b>	<b>6-13</b>
<b>Product Specifications.....</b>	<b>8</b>
<b>Operating Instructions .....</b>	<b>14-16</b>
<b>Intex Pools Operating Time Table.....</b>	<b>17</b>
<b>Non-Intex Pools Operating Time Table.....</b>	<b>18</b>
<b>Maintenance.....</b>	<b>19</b>
<b>Long Term Storage.....</b>	<b>20</b>
<b>Troubleshooting Guide.....</b>	<b>21</b>
<b>Common Pool Problems.....</b>	<b>22</b>
<b>General Aquatic Safety.....</b>	<b>23</b>
<b>Limited Warranty.....</b>	<b>24</b>

# IMPORTANT SAFETY RULES

Read, Understand and Follow All Instructions Carefully Before Installing and Using this Product.

## READ AND FOLLOW ALL INSTRUCTIONS

### WARNING

- To reduce the risk of injury, do not permit children to use this product. Always supervise children and those with disabilities.
- Children must stay away from this product and electrical cord(s).
- Assembly and disassembly by adults only.
- Risk of electric shock. Connect only to a grounding type receptacle, this product is provided with a ground-fault circuit interrupter. If replacement of the plug or cord is needed, use only identical replacement parts.
- Always unplug this product from the electrical outlet before removing, cleaning, servicing or making any adjustment to the product.
- The unit is provided with a ground-fault circuit interrupter (GFCI). To test the GFCI, push the test button. The GFCI should interrupt power. Push the reset button, power should be restored. If the GFCI fails to operate in this manner. The GFCI is defective. If the GFCI interrupts power to the pump without the test button being pushed, a ground current is flowing, indicating the possibility of an electric shock. Do not use this pump. Disconnect the pump and have the problem corrected by a qualified service representative before using.
- Do not bury the electrical cord. Locate the cord where it will not be damaged by lawn mowers, hedge trimmers and other equipment.
- To reduce the risk of electric shock, replace damaged cord immediately. Use a qualified electrician to replace the cord.
- To reduce the risk of electric shock, do not use extension cords, timers, plug adaptors or converter plugs to connect unit to electric supply; provide a properly located outlet.
- Do not attempt to plug in or unplug this product while standing in water or when your hands are wet.
- Do not use an appliance leakage current interrupter (ALCI) in place of a GFCI since the ALCI will not protect people.
- Position this product away from pool, so as to prevent children from climbing on it and access the pool.
- Do not operate this product when pool is occupied.
- To reduce the risk of entrapment hazard, never enter the pool if suction strainer component is loose, broken, cracked, damaged or missing. Replace loose, broken, damaged, cracked or missing suction strainer components immediately.
- Never play or swim near suction fittings. Your body or hair may be trapped causing permanent injury or drowning.
- To prevent equipment damage and risk of injury, always turn pump off before changing the filter control valve position.
- Never operate this product above the maximum working pressure stated on the filter tank.
- Hazardous Pressure. Improper tank valve cover assembly could cause the valve cover to blow off and cause serious injury, property damage or death.
- This product is intended to be used only for the purposes described in the manual!

**FAILURE TO FOLLOW THESE WARNINGS MAY RESULT IN PROPERTY DAMAGE, ELECTRIC SHOCK, ENTANGLEMENT OR OTHER SERIOUS INJURY OR DEATH.**

### CAUTION

This product is for use with storable pools only. Do not use with permanently-installed pools. A storable pool is constructed so that it is capable of being readily disassembled for storage and reassembled to its original integrity. A permanently-installed pool is constructed in or on the ground or in a building such that it cannot be readily disassembled for storage.

These product warnings, instructions and safety rules provided with the product represent some common risks of water recreation devices and do not cover all instances of risk and danger. Please use common sense and good judgement when enjoying any water activity.

# PARTS REFERENCE

Before assembling your product, please take a few minutes to check the contents and become familiar with all the parts.

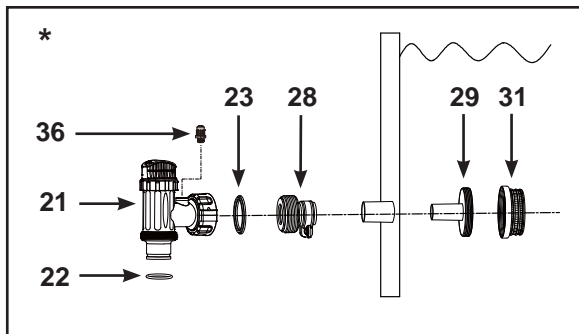
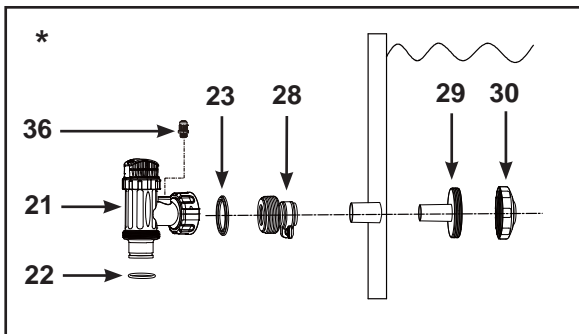
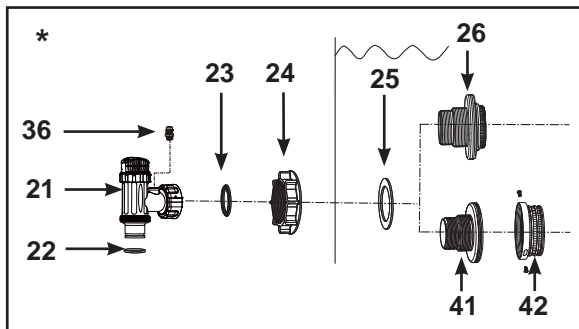
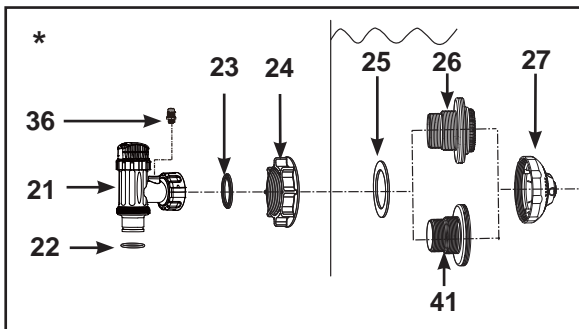
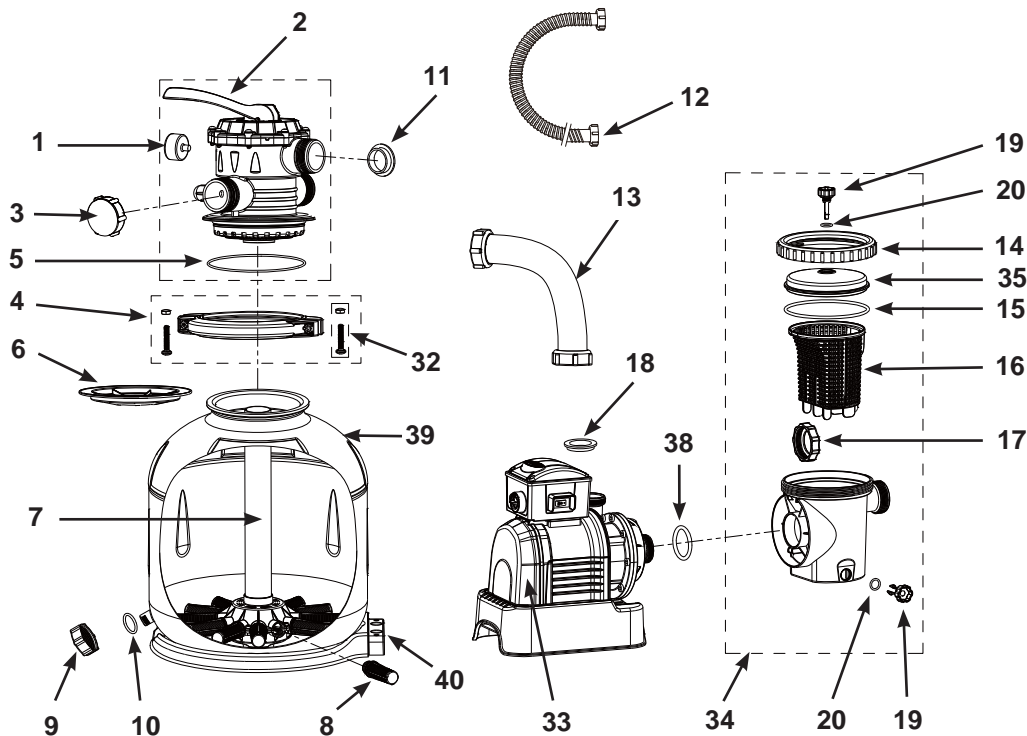

" \* ": Optional.

NOTE: Drawings for illustration purpose only. Actual product may vary. Not to scale.

REF. NO.	DESCRIPTION	QTY.	SPARE PART NO.		
			SF80110	SF70110	SF60110
1	PRESSURE GAUGE	1	11411	11224	11224
2	6-WAY VALVE	1	11378	11496	11496
3	DRAIN OUTLET COVER	1	11131	11131	11131
4	CLAMP	1	11380	11380	11380
5	TANK O-RING	1	11379	11379	11379
6	SAND SHIELD	1	11382	11382	11382
7	CENTER PIPE HUB	1	11815	11813	11814
8	LATERAL	10	11484	11384	11384
9	DRAIN VALVE CAP	1	11456	11456	11456
10	DRAIN VALVE O-RING	1	11385	11385	11385
11	L-SHAPE O-RING	4	11228	11228	11228
12	HOSE WITH NUTS	2	11009	11009	11009
13	SAND FILTER INTERCONNECTING HOSE	1	11820	11388	11535
14	LEAF TRAP NUT	1	11822	11479	11479
15	LEAF TRAP O-RING	1	11824	11232	11232
16	BASKET	1	11821	11260	11260
17	FILTER HOUSING NUT	1	11261	11261	11261
18	L-SHAPE O-RING	1	11412	11412	11412
19	AIR RELEASE VALVE / SEDIMENT RELEASE VALVE	2	10460	10460	10460
20	VALVE O-RING	2	10264	10264	10264
21*	PLUNGER VALVE (HOSE O-RING & STEP WASHER INCLUDED)	2	10747E	10747E	10747E
22*	HOSE O-RING	2	10262	10262	10262
23*	STEP WASHER	2	10745	10745	10745
24*	STRAINER NUT	2	10256	10256	10256
25*	FLAT STRAINER RUBBER WASHER	2	10255	10255	10255
26*	THREADED STRAINER CONNECTOR	2	11235	10744	10744
27*	ADJUSTABLE POOL INLET NOZZLE	1	11074	11074	11074
28*	ADAPTOR B	2	10722	10722	10722
29*	STRAINER CONNECTOR	2	11070	11070	11070
30*	POOL INLET NOZZLE	1	11071	11071	11071
31*	STRAINER GRID	1	11072	11072	11072
32	SCREW	2	11381	11381	11381
33	PUMP MOTOR & CONTROL	1	11817	11805EG	11807EG
34	PRE-FILTER ASSEMBLY	1	11826	11371	11371
35	LEAF TRAP COVER	1	11823	11480	11480
36*	VACUUM RELEASE VALVE	2	11437	11437	11437
37*	VACUUM RELEASE VALVE CAP (NOT SHOWN)	2	11576	11576	11576
38	SAND FILTER PUMP MOTOR INLET O-RING	2	11457	11457	11457
39	SAND FILTER PUMP TANK	1	11804	11802	11803
40	SAND FILTER PUMP TANK BASE	1	11816	11800	11801
41*	THREADED STRAINER CONNECTOR	2			10744
42*	STRAINER GRID	1			10253

" \* ": Optional.

When ordering parts, be sure to quote the model number and part numbers.

## POOL OUTLET - STRAINER & PLUNGER VALVE SETUP (optional)

The strainer grid prevents large objects from jamming and/or damaging the filter pump. If your pool has an inflatable top ring, install the strainer, nozzle and plunger valve before inflating the pool liner top ring. The part numbers here onward refer to the parts depicted in the Parts List section of this manual. To install, do the following:

1. In a counter-clockwise motion unscrew plunger valve union from the threaded strainer connector (26) (see drawing 1). Be careful not to lose the step rubber washer (23). Place the plunger valve on the ground in a safe place.
2. In a counter-clockwise motion unscrew the strainer nut (24) from the threaded connector (26). Leave the flat washer (25) on the connector (26).
3. Install the strainer and plunger valve at the lower position of pool outlet (marked "+"). From the inside of the pool liner insert the connector (26) into one of the pre-cut holes with the washer remaining on the connector to be placed against the inside of the liner wall.
4. Before assembly, lubricate the threads with a petroleum jelly. With the flat side of the strainer nut (24) facing the outside wall of the liner in a clockwise motion screw the strainer nut (24) back onto the threaded connector (26) (see drawing 2).
5. Finger tighten the strainer nut (24) onto the threaded connector (26).
6. Grasp the plunger valve assembly. Make sure the step washer (23) is in place.
7. In a clockwise motion screw the plunger valve union back onto the threaded connector (26) (see drawing 3).
8. In a clockwise motion turn the plunger valve handle to close position. Ensure the plunger valve is securely closed. This will prevent water from flowing out during filling of the pool (see drawing 4.1).
9. **NOTE:** Never cover the vacuum release valve (36) unless it is damaged or leaking. Replace the vacuum release valve immediately.

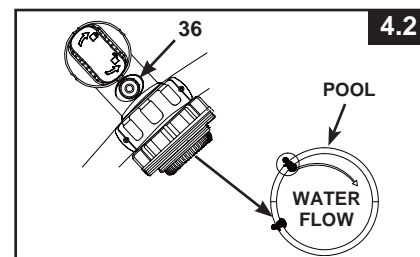
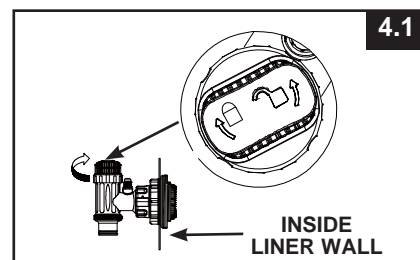
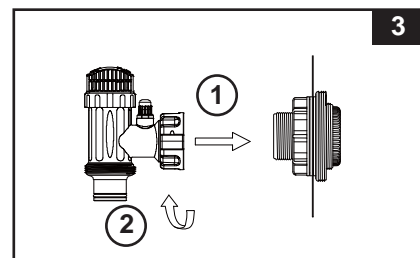
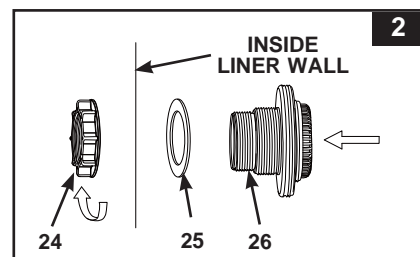
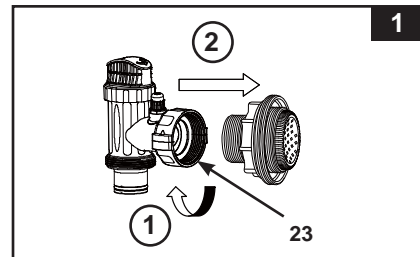

## POOL INLET - NOZZLE & PLUNGER VALVE SETUP (optional)

1. In a counter-clockwise motion unscrew plunger valve union from the threaded strainer connector **(26)** (see drawing 5). Be careful not to lose the step rubber washer **(23)**. Place the plunger valve on the ground in a safe place.
2. In a counter-clockwise motion unscrew the strainer nut **(24)** from the threaded connector **(26)**. Leave the flat washer **(25)** on the connector **(26)**.
3. Install the nozzle and plunger valve at the upper position of pool inlet. From the inside of the pool liner insert the connector **(26)** into one of the pre-cut holes with the washer remaining on the connector to be placed against the inside of the liner wall.
4. Before assembly, lubricate the threads with a petroleum jelly. With the flat side of the strainer nut **(24)** facing the outside wall of the liner in a clockwise motion screw the strainer nut **(24)** back onto the threaded connector **(26)** (see drawing 6).
5. Finger tighten the adjustable pool inlet nozzle **(27)** and the strainer nut **(24)** onto the threaded connector **(26)**.
6. Grasp the plunger valve assembly. Make sure the step washer **(23)** is in place.
7. In a clockwise motion screw the plunger valve union back onto the threaded connector **(26)** (see drawing 7).
8. In a clockwise motion turn the plunger valve handle to close position. Ensure the plunger valve is securely closed. This will prevent water from flowing out during filling of the pool (see drawing 8).
9. **NOTE:** Never cover the vacuum release valve **(36)** unless it is damaged or leaking. Replace the vacuum release valve immediately.
10. Adjust the direction of nozzle head pointing away from the pool outlet for a better circulation result (see drawing 9).
11. The pool liner is now ready to fill with water. Consult the above-ground-pool owner's manual for filling instructions.

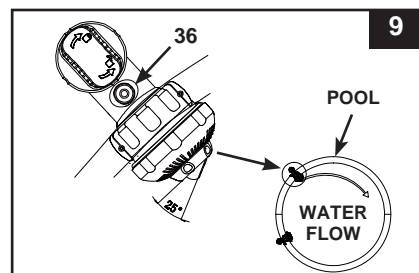
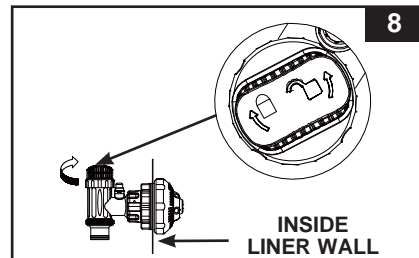
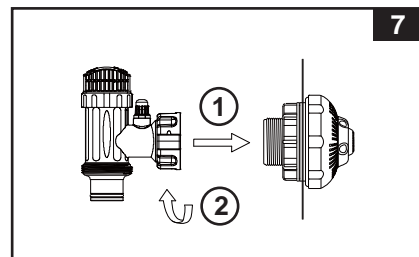
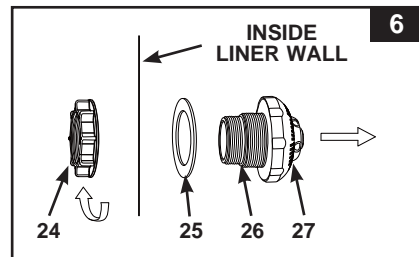
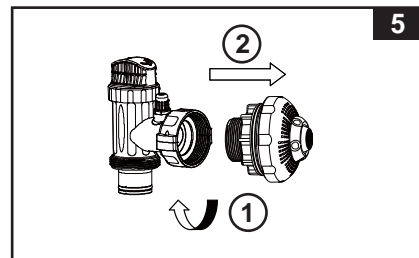



## PRODUCT SPECIFICATIONS

The sand filter removes suspended particles but does not sanitize your pool. Pool chemistry is a specialized area and you should consult your local pool service specialist for details.

Model:	SF80110	SF70110	SF60110
Power:	110-120 Volt AC	110-120 Volt AC	110-120 Volt AC
Amperage:	3 A	4.8 A	6 A
Maximum working pressure:	2 bar (30 psi)	2 bar (30 psi)	2 bar (30 psi)
Effective filtering area:	0.07 m <sup>2</sup> (0.79 ft <sup>2</sup> )	0.1 m <sup>2</sup> (1.07 ft <sup>2</sup> )	0.13 m <sup>2</sup> (1.44 ft <sup>2</sup> )
Maximum Flow Rate:	6055 LPH (1600 GPH)	8140 LPH (2150 GPH)	9275 LPH (2450 GPH)
Recommended filtering media quantity:	No. 20 silica sand 23 Kg (50 Lbs) or glass sand 16 Kg (35 Lbs).	No. 20 silica sand 35 Kg (77 Lbs) or glass sand 25 Kg (55 Lbs).	No. 20 silica sand 55 Kg (121 Lbs) or glass sand 38 Kg (84 Lbs).
Recommended filtering media (Not included):	No. 20 silica sand or glass sand. Particle size range 0.45 to 0.85 mm (0.018 to 0.033 inches). Uniformity Coefficient less than 1.75.		
Limited Warranty:	see "Limited Warranty"		

**NOTE:** NOT SUITABLE FOR USE WITH KCP-LOW -SALT AUTOMATIC SALTWATER SYSTEM (MODEL 6110/6220)

## SETUP INSTRUCTIONS

**TOOLS REQUIRED:** One (1) Phillips screwdriver

**Pump location and mounting:**

- The system must be installed on a solid level and vibration-free base.
- Provide a location protected from the weather, moisture, flooding and freezing temperature.
- Provide adequate access, space and lighting for routine maintenance.
- Pump motor requires free circulation of air for cooling. Do not install the pump in a damp or non-ventilated location.

A team of 2 or more people is recommended for setting up this product.

**Motor pre-filtering assembly setup:**

1. Remove the sand filter and its accessories from the packaging carefully and inspect for any visible damage. For missing or damaged parts contact the appropriate Intex Service Center listed in the separate "Authorized service Centers" sheet.
2. In a counter-clockwise motion unscrew the leaf trap cover (14) from the pre-filter housing. Take out the basket (16) and filter housing nut (17) (see drawing 10).
3. Connect the pre-filter housing to the motor water inlet. Note: Align the connector in the pre-filter housing with the water inlet on the motor (see drawing 11).

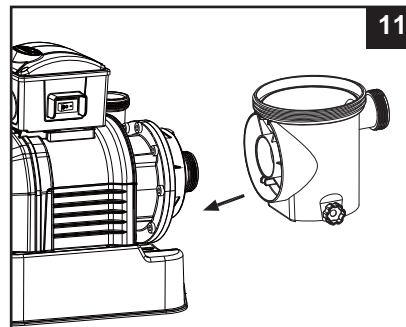
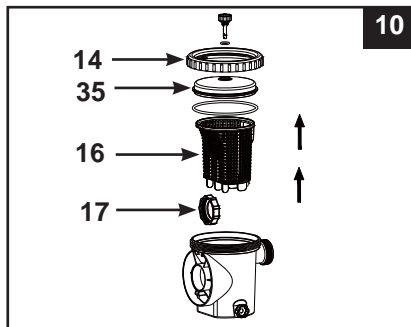



## SETUP INSTRUCTIONS (continued)

4. In a clockwise motion screw filter housing nut (17) onto the motor water inlet (See drawings 12.1 & 12.2).

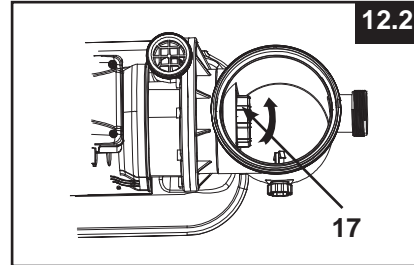
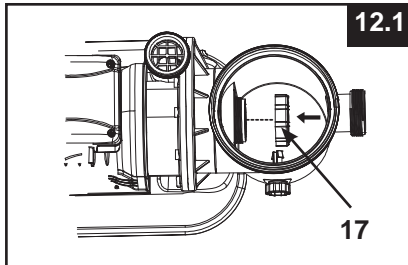

5. Replace the basket (16) and leaf trap cover (14) back to the pre-filter housing (See drawings 13.1 & 13.2).

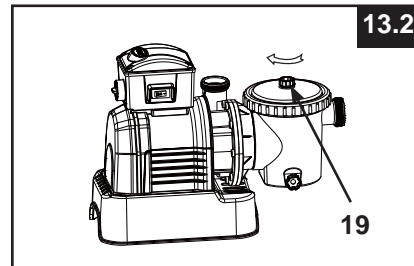
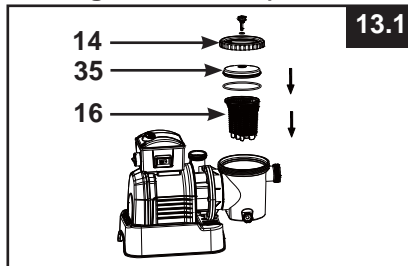

### Sand tank installation:

1. Place the tank support base on the selected location.
2. Place the tank on the tank support base (See drawing 14.1).
3. Connect the motor pre-filtering assembly unit to the tank support base (See drawing 14.2).

NOTE: Ensure the pre-filter housing water inlet hose connection is facing towards the pool.

**IMPORTANT: Some countries, especially in the European community, require the product to be secured to the ground or to a base in a permanent upright position. Check your local authorities to determine if there is a regulation in your area regarding above-the-ground swimming pool filter-pumps. If yes, then the product can be mounted to a platform using the two holes located in the base.**

See drawing 14.3.

The product can be mounted on a cement base or onto a wooden platform to prevent accidental falling over.

- The mounting holes are 6.4 mm in diameter and spaced 100 mm for model SF80110 (spaced 115 mm for model SF70110 & SF60110) apart.
- Use two bolts and lock nuts with a maximum of 6.4 mm in diameter.

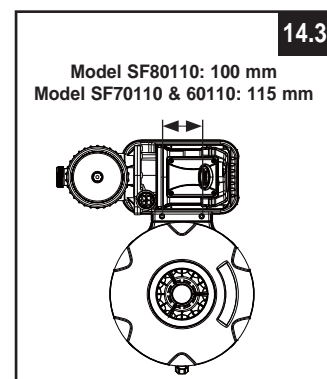
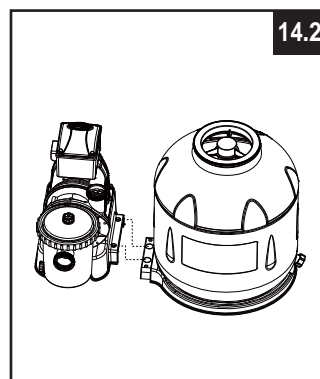
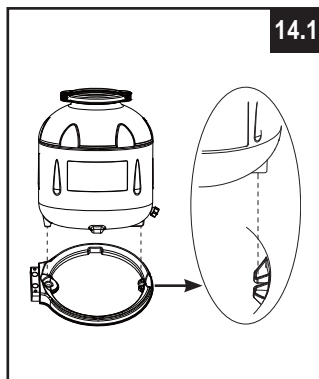

## SETUP INSTRUCTIONS (continued)

### Sand loading:

**IMPORTANT:** Use No. 20 silica sand or glass sand with particle size range 0.45 to 0.85 mm (0.018 to 0.033 inches) and a Uniformity Coefficient less than 1.75.

**NOTE:** Before loading the tank with sand, ensure the center pipe hub assembly is securely in place at the bottom of the tank, and vertically centered inside the tank.

1. Place the sand shield (6) over the top of the center pipe. Pour the sand into the tank at a slow rate. (see drawing 15).
2. Fill the tank approximately half way, remove the sand shield (6) from the top. (see drawing 16).

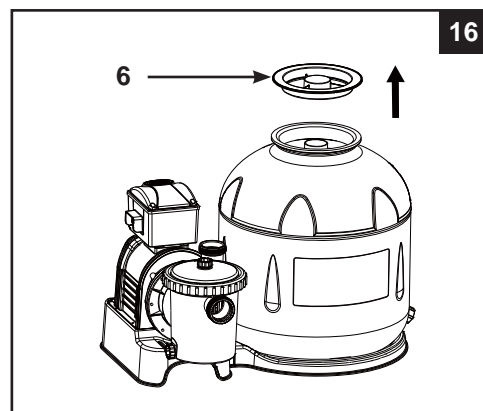
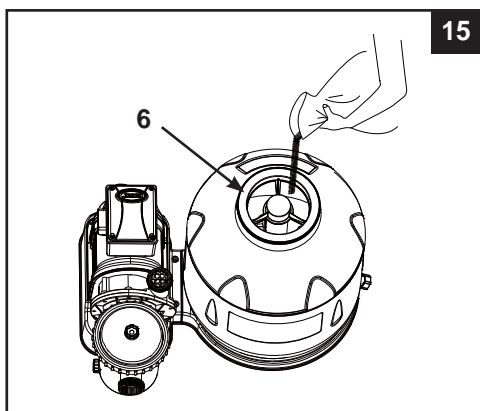

3. Evenly distribute the sand inside the tank, then fill the tank with some water to provide a cushioning effect when the remaining sand is poured in. This prevents the center pipe hub (7) from excessive shock (see drawing 17). Place the sand shield (6) back and continue to pour the sand into the tank.
4. Sand shall be filled between the "MAX" and "MIN" marked gauge on the center pipe. Evenly spread and level out the sand by hand (see drawings 17 & 18).

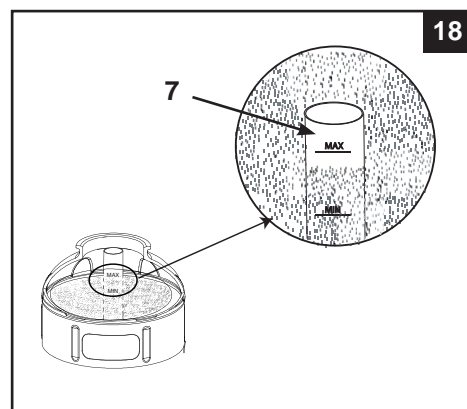
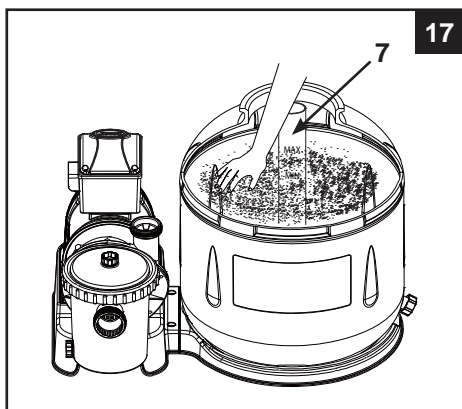

5. Remove the sand shield (6).
6. Wash away all sand around the top edge of the tank.

## SETUP INSTRUCTIONS (continued)

### ⚠ WARNING

Improper tank valve and clamp assembly could cause the valve and clamp to blow off and cause serious injury, property damage or death.

#### 6-way valve installation:

1. Lower the 6-way valve over the tank slowly, and ensure the bypass pipe protruding underneath the 6-way valve fits securely into the center pipe hub (7) top opening (see drawing 19).

**IMPORTANT:** There are three hose connection ports on the 6-way valve, ensure the outlet connection (from filter to the pool) on the valve is facing towards the pool, and the inlet connection (from motor to valve) is aligned with the motor outlet (see drawing 20).

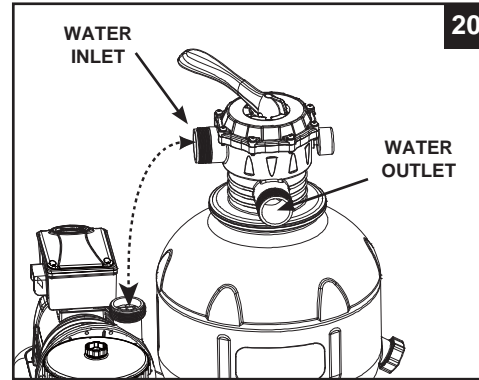
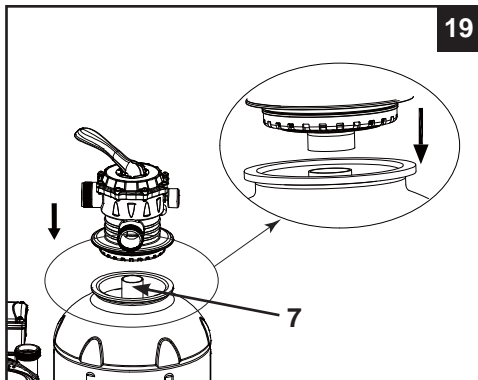

2. Place an L-shape o-ring (11) on the 6-way valve inlet connection and on the pump motor outlet. In a clockwise motion connect the sand filter interconnecting hose (13) between the pump motor outlet and the 6-way valve inlet connection (see drawing 21).
3. Remove the clamp bolt, and install the clamp around the tank and 6-way valve flanges, then replace the clamp bolt and use a phillips screwdriver (not included) to tighten it (see drawings 22).

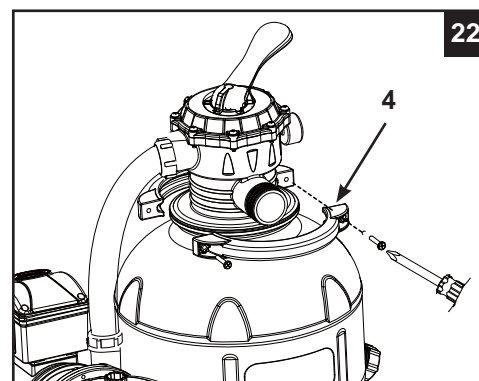
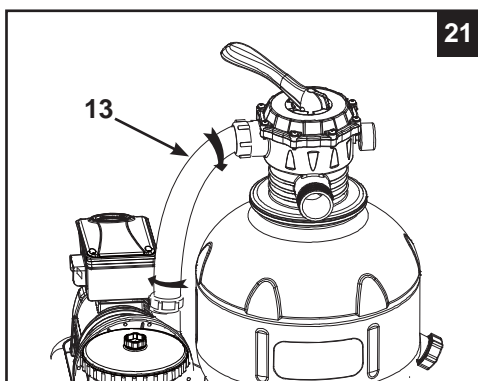

## SAND FILTER PUMP HOSE CONNECTION SETUP

### ⚠ WARNING

- Position this product away from the pool, so as to prevent children from climbing on it and accessing the pool.

#### The 6-way valve has three hose connection ports.

1. Connect one hose (12) end to the pre-filter inlet and the other end of the hose to the lower plunger valve with the strainer. Ensure the hose nuts are securely tightened.
2. Connect the second hose (12) between the 6-way valve water outlet and the upper plunger valve with the inlet-nozzle. Ensure the hose nuts are securely tighten.
3. The third hose connection port (drain/waste outlet) on the 6-way valve shall be directed to a proper draining receptacle using a hose or pipe (not provided). Remove the drain cap before attaching the drain/waste hose or pipe.
4. The sand filter pump is now ready to filter the pool.

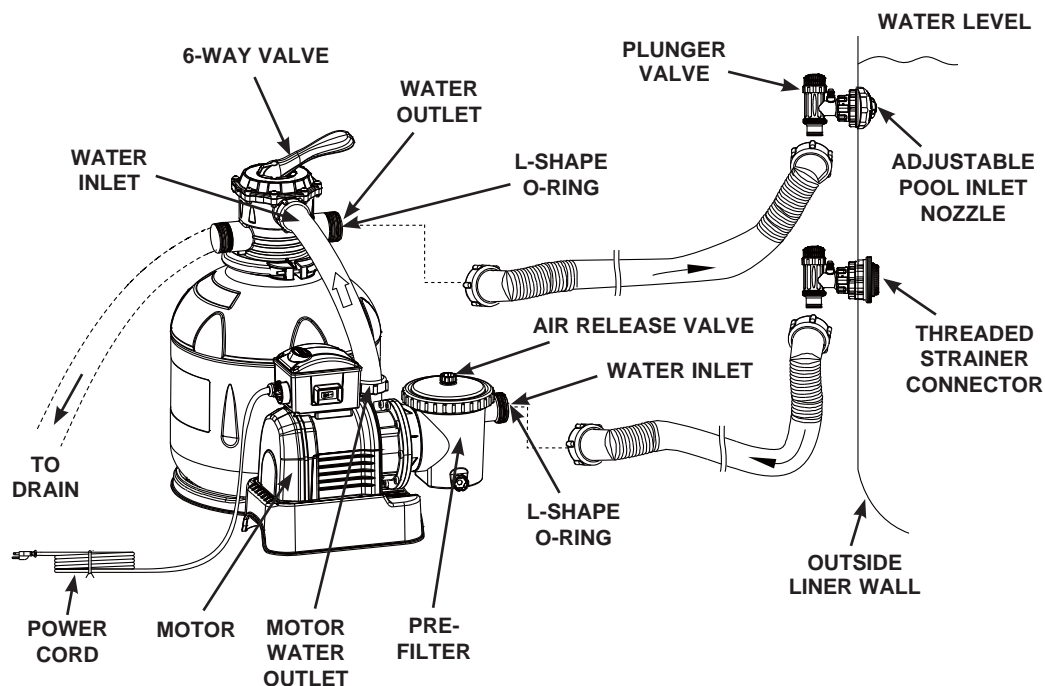

## SAND FILTER PUMP HOSE CONNECTION SETUP (continued)

### For NON-INTEX pool:

Connect the hose (12) to the pool inlet/outlet connection with a large hose clamp. Tighten securely. Remove the drain cap (3) before attaching the drain/waste hose or pipe.

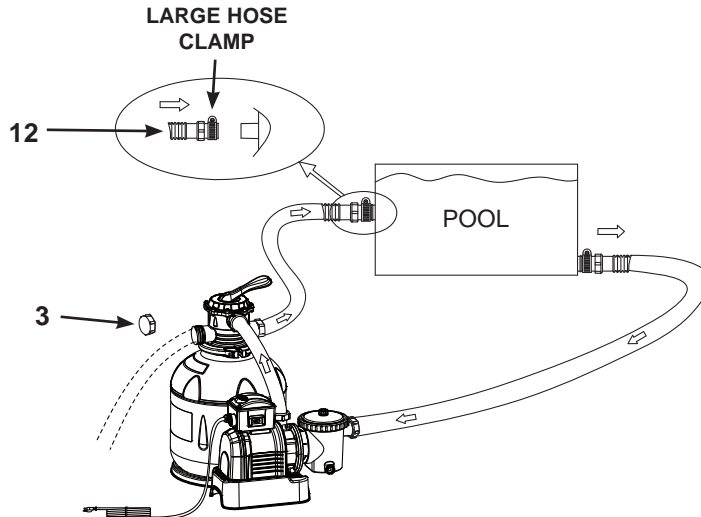

### For INTEX pool size 16' and below:

1. In a counter-clockwise motion unscrew plunger valve union from the threaded strainer connector (26). Be careful not to lose the step rubber washer (23).
2. Grasp the plunger valve assembly. Make sure the step washer (23) is in place. Connect adaptor B (28) to plunger valve union.
3. Remove wall plug and then insert the strainer (29 & 31) into the lower position of protruding hose connection, and the nozzle (29 & 30) into the upper position of protruding hose connection. Adaptor B (28) fits over the strainer connection (29) inserted into the connection. Tighten securely.
4. Remove the drain cap (3) before attaching the drain/waste hose or pipe.

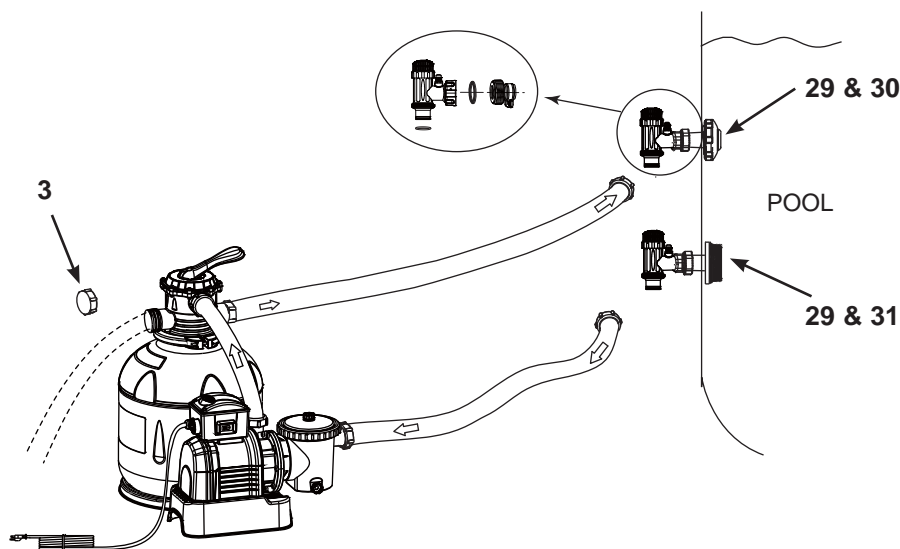

## OPERATING INSTRUCTIONS

### ⚠ WARNING

- Risk of electric shock. Connect this product only to a grounding type receptacle protected by a ground-fault circuit interrupter (GFCI) or residual current device (RCD). Contact a qualified electrician if you cannot verify that the receptacle is protected by a GFCI/RCD. Use a qualified electrician to install the GFCI/RCD, which has a maximum rate of 30mA. Do not use a portable residual current device (PRCD).
- To reduce the risk of electric shock, do not use extension cords, timers, plug adaptors or converter plugs to connect unit to electric supply; provide a properly located outlet.
- Do not attempt to plug in or unplug this product while standing in water or when your hands are wet.
- Never operate this product above the maximum working pressure stated on the filter tank.
- Always switch off pump before changing the 6-way valve position.
- Operating this product without water flowing through the system can cause a build up of hazardous pressure which can result in an explosive situation, serious injury, property damage or death.
- Never test this pump with compressed air. Never operate the system with water temperature above 35° C (95° F).

#### 6-way valve positions and function:

Valve Position	Function	Water Flow Direction
<b>FILTER</b> (see drawing 23)	Normal filtration and regular vacuuming of pool	From pump through filter media to pool
<b>BACKWASH</b> (see drawing 24)	Reverses water flow to clean filter media	From pump through filter media to valve waste/drain outlet
<b>RINSE</b> (see drawing 25)	For initial startup cleaning of the sand, and leveling the sand bed after backwashing	From pump through filter media to valve waste/drain outlet
<b>WASTE</b> (see drawing 26)	For vacuuming directly to waste, lowering pool level or to drain the pool	From pump to valve waste/drain outlet bypassing the filter media
<b>RECIRCULATE</b> (see drawing 27)	For circulating water back to pool without going through the filter media	From pump through valve to pool bypassing the filter media
<b>CLOSED</b> (see drawing 28)	Shuts off all flow to filter and pool "Do not use this setting with pump running"	

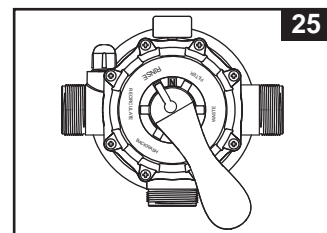
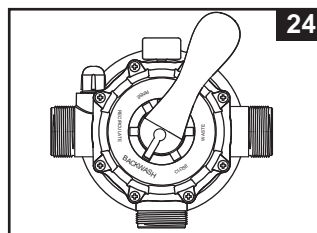
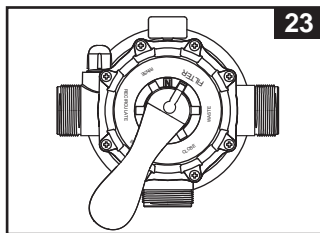

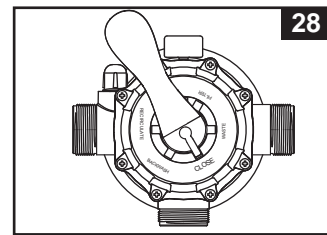
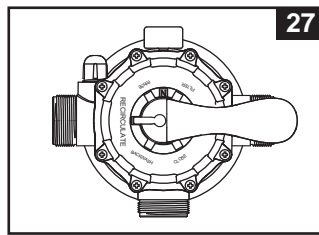
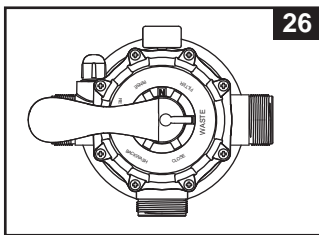

## OPERATING INSTRUCTIONS (continued)

**Initial startup and operation:****Before operating, be sure that:**

- All the hoses have been connected and tightened securely, and correct amount of filter sand have been loaded.
- The entire system is connected to a grounding type receptacle protected by a ground-fault circuit interrupter (GFCI) or residual current device (RCD).

**CAUTION**

**The filter control valve has a closed position. The pump should never be on when the valve is in the closed position. If the pump is operated with the valve closed, explosive situation could exist.**

1. Turn both plunger valve handles fully counter-clockwise until they stop. This opens the valves to allow water to flow into the sand filter pump. With water flowing into sand filter pump, the water pressure will allow the air trapped inside to escape from the air release valves (19). When all the air has escaped water will flow out of the valves (19). When this occurs gently finger tighten the valves (19) in a clockwise direction.

**IMPORTANT: To prevent air lock, open the lower plunger valve (connected inlet hose) first and then the upper plunger valve (connected outlet hose). Open the air release valves, wait until water starts to flow out of the air release valves, close air release valves.**

**NOTE:** The plunger valve is equipped with a vacuum release valve that will automatically activate to minimize the suction at the pool outlet if the outlet is blocked. This is an additional safety feature to prevent suction entrapment. The vacuum release valve will reset once the blockage is removed and the pump is switched off. To restart the system the air must be removed from the filter pump per previous step.

2. Ensure the drain/waste outlet on the 6-way valve is not covered and directed to a proper draining receptacle.
3. Ensure the pump is off, depress the 6-way valve and turn it to the "BACKWASH" position (see drawings 24 & 29). **IMPORTANT: To prevent damage to the 6-way valve, always depress the valve handle before turning. Always switch off pump before changing the 6-way valve position.**
4. Switch on the pump (see drawing 30). Water is circulating backward through the pump and to waste/drain outlet. Backwash until a clear flow of water is observed in the waste/drain outlet or through the drain sediment window. **NOTE:** The initial backwash of the filter is recommended to remove any impurities or fine sand particles in the sand media.

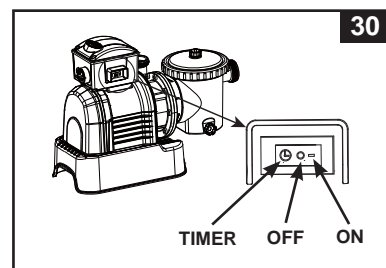
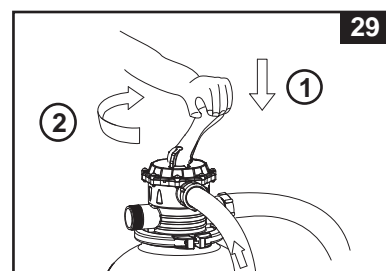



## OPERATING INSTRUCTIONS (continued)

5. Switch off the pump, change the 6-way valve to "RINSE" position (**see drawing 25**).
6. Switch on the pump and run the pump for about one minute to level out the sand bed after backwashing the sand media.
7. Switch off the pump, change the 6-way valve to "FILTER" position (**see drawing 23**).
8. Switch on the pump. The system is now operating in the normal filtering mode. Run the pump until the desired pool water clearance is obtained and no more than 12 hours per day.
9. Record the initial pressure gauge reading when the filter media is clean.

**NOTE:** During initial setup of the system, it may be necessary to backwash frequently due to unusual heavy dirt present in the water and sand. After that, as the filter removes dirt and impurities from the pool water, the accumulated dirt in the sand media will cause the pressure to rise and the flow to diminish. If there is no vacuuming device attached to the system and the pressure gauge reading is in the yellow zone it is time to backwash the sand media, see "BACKWASH" under "initial startup and operation" section. Vacuuming device (i.e. Intex auto pool cleaner) attached to the system may also cause the flow to diminish and the pressure to rise. Remove any vacuuming device from the system and check if the pressure gauge reading has dropped from the yellow zone to the green zone.

### Operating the system under "TIMER" mode or manually:

#### To operate the sand filter pump in "FILTER" mode under "TIMER" control:

- A. Set the timer dial to the desired operating hours. See operation time table (**see drawing 31**).
- B. Turn on the pump by pressing the switch to "⊕" position, the sand filter pump is now filtering the water and will stop after the operating hours are completed. The built-in timer will now operate for the number of hours selected at the same time each day.
- C. Operating hours can be re-adjusted if necessary. Follow step A – B.

#### To operate the sand filter pump manually (without the "TIMER" mode):

- A. Turn on the pump by pressing the switch to "⊕" position, the sand filter pump is now filtering the water.
- B. To turn off the pump, press the switch to "O" position.

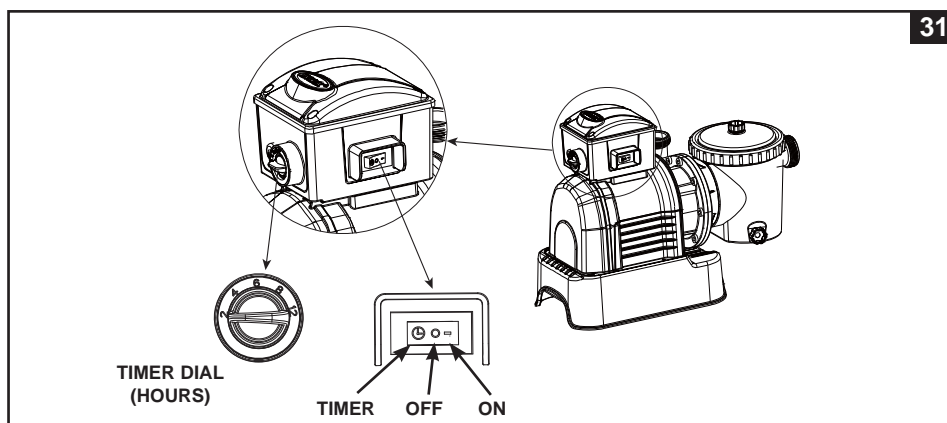

## IMPORTANT

If you continue to experience difficulty, please contact our Consumer Service Department for assistance. See separate "Authorized Service Centers" sheet.

## INTEX POOLS OPERATING TIME TABLE (WITHOUT INTEX SALTWATER SYSTEM)

This table shows the required operating time for average use of the sand filter pump with above ground pools.

If the system is attached to an "Intex Saltwater System" unit, the filter pump running time should be longer than the required operating time of the Intex Saltwater System unit.

Pool Size	Water Capacity (Calculated at 90% for Frame Pool and 80% for Easy Set & Oval Pool)		Sand filter pump operating time (For one cycle) / (Hours)			
	(Gals)	(Liters)	SF80110	SF70110	SF60110	
<b>INTEX ABOVE GROUND POOLS (AGP's)</b>						
<b>EASY SET® POOL</b>	457cmx84cm(15'x33")	2587	9792	2		
	457cmx91cm(15'x36")	2822	10681	2		
	457cmx107cm(15'x42")	3284	12430	2		
	457cmx122cm(15'x48")	3736	14141	4		
	488cmx107cm(16'x42")	3754	14209	4		
	488cmx122cm(16'x48")	4273	16173	4		
	488cmx132cm(16'x52")	4614	17464	4		
	549cmx107cm(18'x42")	4786	18115	4	2	2
	549cmx122cm(18'x48")	5455	20647	4	2	2
<b>ROUND METAL FRAME POOL</b>	457cmx91cm(15'x36")	3282	12422	2		
	457cmx107cm(15'x42")	3861	14614	4		
	457cmx122cm(15'x48")	4440	16805	4		
	488cmx122cm(16'x48")	5061	19156	4		
	549cmx122cm(18'x48")	6423	24311	6	4	4
	640cmx132cm(21'x52")	9533	36082	6	4	4
	732cmx132cm(24'x52")	12481	47241	8	6	6
<b>ULTRA FRAME POOL</b>	488cmx122cm(16'x48")	5061	19156	4		
	549cmx122cm(18'x48")	6423	24311	4	4	4
	549cmx132cm(18'x52")	6981	26423	6	4	4
	610cmx122cm(20'x48")	7947	30079	6	4	4
	671cmx132cm(22'x52")	10472	39637	8	4	4
	732cmx132cm(24'x52")	12481	47241	8	6	6
	792cmx132cm(26'x52")	14667	55515	12	8	8
<b>SEQUOIA SPIRIT® POOL SET</b>	478cmx124cm(15'8"x49")	4440	16805	4		
	508cmx124cm(16'8"x49")	5061	19156	4	2	2
	569cmx135cm(18'8"x53")	6981	26423	6	4	4
<b>OVAL FRAME POOL</b>	305cmx549cmx107cm(10'x18'x42")	2885	10920	2		
	366cmx610cmx122cm(12'x20'x48")	4393	16628	4	2	2
<b>RECT. ULTRA FRAME POOL</b>	274cmx457cmx122cm(9'x15'x48")	3484	13187	4	2	2
	274cmx549cmx132cm(9'x18'x52")	4545	17203	4	2	2
	305cmx610cmx132cm(10'x20'x52")	5835	22085	4	4	2
	366cmx732cmx132cm(12'x24'x52")	8403	31805	6	4	4
	488cmx975cmx132cm(16'x32'x52")	14364	54368	12	8	6

NOTE: The "12" hours timer setting position has an additional 20 minutes over the actual setting.

## NON-INTEX POOLS OPERATING TIME TABLE

This table shows the required operating time for average use of the sand filter pump with above ground pools.

Water Capacity		Sand filter pump operating time (For one cycle) / (Hours)		
(Gals)	(Liters)	SF80110	SF70110	SF60110
3000	11355	2		
4000	15140	4	2	2
4440	16805	4	2	2
5000	18925	4	2	2
6000	22710	4	4	2
7000	26495	6	4	4
8000	30280	6	4	4
9000	34065	6	4	4
10000	37850	8	6	4
11000	41635	8	6	4
12000	45420	8	6	6
13000	49205	12	6	6
14000	52990	12	8	6
15000	56775	12	8	6
16000	60560	12	8	6
17000	64345	12	8	8
18000	68130	12	12	8
19000	71915	12	12	8
20000	75700		12	8
21000	79485		12	12
22000	83270		12	12
23000	87055		12	12
24000	90840		12	12
25000	94625		12	12
26000	98410		12	12

## MOTOR PRE-FILTER CLEANING AND MAINTENANCE

1. Make sure the filter pump is switched off, then disconnect the power cord from the electrical outlet.
2. Turn both plunger valve handles fully clockwise until they stop. This closes the valve, prevents the water from flowing out of the pool.
3. Release the pressure first by opening the sediment release valve **(19)** located on the lower side of the pre-filter housing (**see drawing 32**).

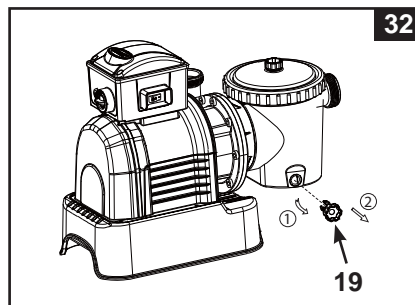

4. In a counter-clockwise motion unscrew the leaf trap cover **(14)**, then remove the basket **(16)** and leaf trap o-ring **(15)** from the pre-filter housing (**see drawing 33**).

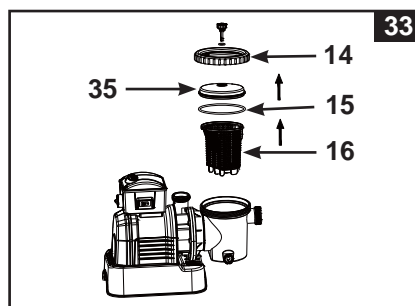

5. Empty and flush the basket using a garden hose, may use a plastic brush to remove deposits from the basket. Do not use metal brush.
6. Clean and rinse the inside of the pre-filter housing and the leaf trap O-ring with a garden hose.
7. Reinstall the leaf trap O-ring, basket and leaf trap cover to the pre-filter housing.
8. Close the sediment release valve **(19)** back.

## POOL CARE & CHEMICALS

- All pools require care to keep the water clear and hygienically clean. With proper chemical control, your filter will help attain this objective. Consult your pool supply dealer for instructions regarding the proper use of chlorine, algaecide and other chemical agents required for sparkling clear water.
- Keep pool chemicals away from children.
- Do not replenish chemicals in pool while pool is occupied. Skin or eye irritations could occur.
- Daily pH checking and chemical treatment of the water is very important and cannot be overemphasized. Chlorine, algaecide and maintenance of proper pH levels are required when filling the pool as well as during the season. Consult your local swimming pool supply store for instructions.
- The season's first filling of the pool may have brackish water requiring extra water additives and extra filtering time. Do not allow swimming in pool until the pH level is balanced. Consult your local swimming pool supply store for instructions.
- Chlorinated water may damage lawns, gardens or shrubbery as children play in the pool and splash water outside the pool. Lawn areas underneath the pool liner will be destroyed. Note that some types of grass may grow through the liner.
- Filter run time depends on pool size, weather and usage level. Experiment with various run times so as to produce clean clear water.

### CAUTION

**Concentrated chlorine solutions may damage the pool liner. Always follow the chemical manufacturer's directions, and the health and hazard warnings.**

## LONG TERM STORAGE & WINTERIZATION

### CAUTION

**Allowing the water to freeze will damage the sand filter and void the warranty. If anti-freeze solution is needed, use only propylene glycol. Propylene glycol is non-toxic and will not damage plastic system components; other anti-freezes are highly toxic and may damage plastic components in the system.**

1. Before emptying your pool for long term storage, or relocation, be sure the water is directed towards an acceptable drain water receptacle away from the house. Check local regulations for specific directions regarding disposal of swimming pool water.
2. Switch off the unit, and disconnect power cord from electrical outlet.
3. When the pool is empty, disconnect all hoses from pump and plunger valves and remove the strainers/plunger valves from the pool wall.
4. In a counter clockwise motion unscrew the drain valve cap **(9)** from the drain valve to thoroughly drain the tank. The drain valve is located at the bottom of the filter tank.
5. Disassemble the pump motor from the tank base.
6. Leave sand filter pump pieces and hoses outside to thoroughly air dry.
7. Coat the following o-rings and washers with petroleum jelly for long term storage:
  - L-shape o-rings **(11 & 18)**.
  - Pump hose O-rings **(22)**.
  - Strainer valve assembly step washers **(23)**.
  - Flat strainer rubber washers **(25)**.
8. Depress the 6-way valve handle and rotate so as to set the pointer on the valve top "N" position. This allows the water to drain from the valve. Leave the 6-way valve in this inactive position.
9. It is best to place all dry pieces and pump motor in the original packaging for storage. To avoid condensation or corrosion problem, do not cover or wrap pump motor with plastic bags.
10. Store the pump motor and accessories in a dry place. The storage's temperature should be controlled, between 0 degrees Celsius (32 degrees Fahrenheit) and 40 degrees Celsius (104 degrees Fahrenheit).

## TROUBLESHOOTING GUIDE

TROUBLE	CAUSE	SOLUTION
FILTER MOTOR FAILS TO START	<ul style="list-style-type: none"> <li>The motor is not plugged in.</li> <li>The GFCI/RCD circuit breaker is tripped.</li> <li>Motor too hot and overload protection is shut off.</li> </ul>	<ul style="list-style-type: none"> <li>Line cord must be plugged into a 3 wire outlet that is protected by a Class A Ground Fault Circuit Interrupter, or RCD.</li> <li>Reset circuit breaker. If circuit breaker trips repeatedly, your electrical system may have a defect. Turn off circuit breaker and call an electrician to correct the problem.</li> <li>Let the motor cool down and restart again.</li> </ul>
FILTER DOESN'T CLEAN POOL	<ul style="list-style-type: none"> <li>Improper chlorine or pH levels.</li> <li>No filtering media in tank.</li> <li>Wrong 6-way valve setting position.</li> <li>Excessively dirty pool.</li> <li>The strainer screen is restricting the water flow.</li> </ul>	<ul style="list-style-type: none"> <li>Adjust the chlorine and pH level. Consult your local swimming pool supply stores.</li> <li>Load with filter sand, see "sand loading instructions".</li> <li>Set valve to "FILTER" position.</li> <li>Operate the filter for longer periods.</li> <li>Clean the strainer screen at the inlet.</li> </ul>
FILTER DOESN'T PUMP WATER OR FLOW IS VERY SLOW	<ul style="list-style-type: none"> <li>Clogged inlet or discharge.</li> <li>An air leak on the intake line.</li> <li>Excessively dirty pool.</li> <li>Sand media clogged with dirt.</li> <li>Nozzle and strainer connections are reversed.</li> <li>Crusting or caking on the filtering sand surface.</li> <li>Pool vacuuming device attached to the system.</li> <li>The vacuum release valve on the plunger valve is activated.</li> <li>The vacuum release valve on the plunger valve is leaking.</li> </ul>	<ul style="list-style-type: none"> <li>Clear any obstructions in the intake hose by discharging it inside pool wall.</li> <li>Tighten hose nuts, check hoses for damage, check pool water level.</li> <li>Clean the pre-filtering basket more often.</li> <li>Backwash filter.</li> <li>Install the nozzle at the upper position of the pool inlet, and the strainer at the lower position of the pool outlet.</li> <li>Remove about 1" of sand if necessary.</li> <li>Remove any pool vacuuming device attached to the system line.</li> <li>Turn off pump, clear any debris or obstruction in the outlet, remove all air from the filter pump and turn pump on again.</li> <li>Turn off pump, if water leaking from the vacuum release valve, then release valve needs to be replaced. Contact Intex Service Center immediately to order replacement. You may cover release valve with the cap temporarily if you ensure that the strainer cover / strainer grid is installed and you <b>Do Not</b> run the pump while pool is occupied.</li> </ul>
PUMP DOESN'T WORK	<ul style="list-style-type: none"> <li>Low water level.</li> <li>Strainer screen clogged up.</li> <li>An air leak on the intake hose.</li> <li>Faulty motor or the impeller is jammed.</li> </ul>	<ul style="list-style-type: none"> <li>Fill pool to correct water level.</li> <li>Clean strainer screens at pool inlet.</li> <li>Tighten hose nuts, check hose for damage.</li> <li>Contact Intex service center.</li> </ul>
6-WAY VALVE/ COVER LEAKING	<ul style="list-style-type: none"> <li>Sand tank o-ring missing.</li> <li>Sand tank o-ring dirty.</li> <li>Flange clamp not tight.</li> <li>6-way valve damage.</li> </ul>	<ul style="list-style-type: none"> <li>Remove 6-way valve cover and ensure the o-ring is in place.</li> <li>Clean sand tank o-ring with garden hose water.</li> <li>Tighten the clamp with wrench supplied.</li> <li>Contact Intex service center.</li> </ul>
HOSE LEAKING	<ul style="list-style-type: none"> <li>Hose nut not securely tight.</li> <li>Hose connection fitting o-ring/L-shape o-ring missing.</li> </ul>	<ul style="list-style-type: none"> <li>Tighten/reinstall hose nut.</li> <li>Ensure o-ring/L-shape o-ring is in place and not damaged.</li> </ul>
TIMER IS INACCURATE OR TIMER CAN'T BE SET	<ul style="list-style-type: none"> <li>Possible inner timer defective.</li> </ul>	<ul style="list-style-type: none"> <li>Turn off the pump and restart 5 minutes later.</li> <li>Re-set the timer.</li> <li>Contact Intex service center.</li> </ul>
PRESSURE GAUGE DOESN'T WORK	<ul style="list-style-type: none"> <li>Clogged inlet of the pressure gauge.</li> <li>Pressure gauge damage.</li> </ul>	<ul style="list-style-type: none"> <li>Clear any obstructions in the intake by unscrewing it from the 6-way valve.</li> <li>Contact Intex service center.</li> </ul>
SAND IS FLOWING BACK INTO THE POOL	<ul style="list-style-type: none"> <li>Sand is too small.</li> <li>Sand bed is calcified.</li> </ul>	<ul style="list-style-type: none"> <li>Use only No. 20 silica sand with particle size range 0.45 to 0.85 mm (0.018 to 0.033 inches) and a Uniformity Coefficient less than 1.75.</li> <li>Change sand.</li> </ul>

## COMMON POOL PROBLEMS

PROBLEM	DESCRIPTION	CAUSE	SOLUTION
ALGAE	<ul style="list-style-type: none"> <li>• Greenish water.</li> <li>• Green or black spots on pool liner.</li> <li>• Pool liner is slippery and/or has a bad odor.</li> </ul>	<ul style="list-style-type: none"> <li>• Chlorine and pH levels need adjustment.</li> </ul>	<ul style="list-style-type: none"> <li>• Super chlorinate with shock treatment. Correct pH to your pool store's recommended level.</li> <li>• Vacuum pool bottom.</li> <li>• Maintain proper chlorine level.</li> </ul>
COLORED WATER	<ul style="list-style-type: none"> <li>• Water turns blue, brown, or black when first treated with chlorine.</li> </ul>	<ul style="list-style-type: none"> <li>• Copper, iron or manganese in water being oxidized by the added chlorine. This is Common.</li> </ul>	<ul style="list-style-type: none"> <li>• Adjust pH level to the recommended level.</li> <li>• Run filter until water is clear.</li> </ul>
FLOATING MATTER IN WATER	<ul style="list-style-type: none"> <li>• Water is cloudy or milky.</li> </ul>	<ul style="list-style-type: none"> <li>• "Hard water" caused by a too high pH level.</li> <li>• Chlorine content is low.</li> <li>• Foreign matter in water.</li> </ul>	<ul style="list-style-type: none"> <li>• Correct the pH level. Check with your pool dealer for advice.</li> <li>• Adjust the chlorine level.</li> </ul>
CHRONIC LOW WATER LEVEL	<ul style="list-style-type: none"> <li>• Level is lower than on previous day.</li> </ul>	<ul style="list-style-type: none"> <li>• Rip or hole in pool liner or hoses.</li> <li>• The drain valves are loose.</li> </ul>	<ul style="list-style-type: none"> <li>• Repair with a patch kit.</li> <li>• Finger tighten all caps.</li> </ul>
SEDIMENT ON POOL BOTTOM	<ul style="list-style-type: none"> <li>• Dirt or sand on pool floor.</li> </ul>	<ul style="list-style-type: none"> <li>• Heavy use, getting in and out of pool.</li> </ul>	<ul style="list-style-type: none"> <li>• Use Intex pool vacuum to clean bottom of pool.</li> </ul>
SURFACE DEBRIS	<ul style="list-style-type: none"> <li>• Leaves, insects etc.</li> </ul>	<ul style="list-style-type: none"> <li>• Pool too close to trees.</li> </ul>	<ul style="list-style-type: none"> <li>• Use Intex pool skimmer.</li> </ul>

Operation is subject to the following two conditions: (1) this device may not cause interference, and (2) this device must accept any interference, including interference that may cause undesired operation of the device.

Changes or modifications not expressly approved by the party responsible for compliance could void the user's authority to operate the equipment.

This equipment has been tested and found to comply with the limits for Class B digital device, pursuant to part 15 of the FCC Rules. These limits are designed to provide reasonable protection against harmful interference in a residential installation. This equipment generates, uses and can radiate radio frequency energy and, if not installed and used in accordance with the instructions, may cause harmful interference to radio communications. However, there is no guarantee that interference will not occur in a particular installation. If this equipment does cause harmful interference to radio or television reception, which can be determined by turning the equipment off and on, the user is encouraged to try to correct the interference by one or more of the following measures:

- Reorient or relocate the receiving antenna.
- Increase the separation between the equipment and the receiver.
- Connect the equipment into an outlet on a circuit different from that to which the receiver is connected.
- Consult the dealer or an experienced radio/TV technician for help.



## GENERAL AQUATIC SAFETY

**Water recreation is both fun and therapeutic. However, it involves inherent risks of injury and death. To reduce your risk of injury, read and follow all product, package and package insert warnings and instructions. Remember, however, that product warnings, instructions and safety guidelines cover some common risks of water recreation, but do not cover all risks and dangers.**

**For additional safeguards, also familiarize yourself with the following general guidelines as well as guidelines provided by nationally recognized Safety Organizations:**

- Demand constant supervision. A competent adult should be appointed as a “lifeguard” or water watcher, especially when children are in and around the pool.
- Learn to swim.
- Take the time to learn CPR and first aid.
- Instruct anyone who is supervising pool users about potential pool hazards and about the use of protective devices such as locked doors, barriers, etc.
- Instruct all pool users, including children what to do in case of an emergency.
- Always use common sense and good judgement when enjoying any water activity.
- Supervise, supervise, supervise.

**For additional information on safety, please visit**

- **The Association of Pool and Spa Professionals: The Sensible Way to Enjoy Your Aboveground/Onground Swimming Pool** [www.nspi.org](http://www.nspi.org)
- **American Academy of Pediatrics: Pool Safety for Children** [www.aap.org](http://www.aap.org)
- **Red Cross** [www.redcross.org](http://www.redcross.org)
- **Safe Kids** [www.safekids.org](http://www.safekids.org)
- **Home Safety Council: Safety Guide** [www.homesafetycouncil.org](http://www.homesafetycouncil.org)
- **Toy Industry Association: Toy Safety** [www.toy-tia.org](http://www.toy-tia.org)

## LIMITED WARRANTY

Your Sand Filter Pump has been manufactured using the highest quality materials and workmanship. All Intex products have been inspected and found free of defects prior to leaving the factory. This Limited Warranty applies only to the Sand Filter Pump and accessories listed below.

The provisions of this Limited Warranty apply only to the original purchaser and is not transferable. This Limited Warranty is valid for the period noted below from the date of the initial retail purchase. Keep your original sales receipt with this manual, as proof of purchase will be required and must accompany warranty claims or the Limited Warranty is invalid.

Sand Filter Pump Warranty – 2 Years

Hoses, Plunger Valves & Fittings Warranty – 180 days

If a manufacturing defect is found within the periods noted above, please contact the appropriate Intex Service Center listed in the separate "Authorized Service Centers" sheet. The Service Center will determine the validity of the claim. If the Service Center directs you to return the product, please carefully package the product and send with shipping and insurance prepaid to the Service Center. Upon receipt of the returned product, the Intex Service Center will inspect the item and determine the validity of the claim. If the provisions of this warranty cover the item, the item will be repaired or replaced at no charge.

Any and all disputes regarding the provisions of this Limited Warranty shall be brought before an informal dispute settlement board and unless and until the provisions of these paragraphs are carried forth, no civil action may be instituted. The methods and procedures of this settlement board shall be subject to the rules and regulations set forth by the Federal Trade Commission (F.T.C.). IMPLIED WARRANTIES ARE LIMITED TO THE TERMS OF THIS WARRANTY AND IN NO EVENT SHALL INTEX, THEIR AUTHORIZED AGENTS OR EMPLOYEES BE LIABLE TO THE BUYER OR ANY OTHER PARTY FOR DIRECT OR CONSEQUENTIAL DAMAGES OR LIABILITIES. Some states, or jurisdictions do not allow the exclusion or limitation of incidental or consequential damages, so the above limitation or exclusion may not apply to you.

This Limited Warranty does not apply if the products are subject to negligence, abnormal use or operation, accident, improper operation, improper voltage or current contrary to operating instructions, or to damage by circumstances beyond Intex's control, including but not limited to, ordinary wear and tear and damage caused by exposure to fire, flood, freezing, rain, or other external environmental forces. This Limited Warranty applies only to those parts and components sold by Intex. The Limited Warranty does not cover unauthorized alterations, repairs or disassembly by anyone other than Intex Service Center personnel.

**DO NOT GO BACK TO THE PLACE OF PURCHASE FOR RETURN OR REPLACEMENT. IF YOU ARE MISSING PARTS OR NEED ASSISTANCE, PLEASE CALL US TOLL-FREE (FOR U.S. AND CANADIAN RESIDENTS): 1-800-234-6839 OR VISIT OUR WEBSITE: WWW.INTEXSTORE.COM.**

Proof of Purchase must accompany all returns or the warranty claim will be invalid.